

Operator's manual



TruTool S 160 (2A1)

TRUMPF GmbH + Co. KG, Technische Redaktion
Johann-Maus-Straße 2, D-71254 Ditzingen
Fon: +49 7156 303 - 0
Internet: <http://www.trumpf.com>
E-Mail: docu.tw@de.trumpf.com

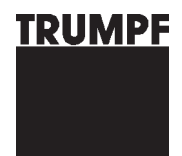

Table of contents

1	Safety	2
1.1	General safety information	2
1.2	Specific safety information for seam locker	2
2	Description	4
2.1	Intended use	4
2.2	Technical data	5
2.3	Icons	5
2.4	Noise and vibration information	6
3	Setting work	8
3.1	Selecting blades	8
3.2	Setting cutting clearance	9
4	Operation	11
4.1	Switching TruTool S 160 (2A1) on and off	11
4.2	Working with TruTool S 160 (2A1)	11
5	Maintenance	13
5.1	Changing blade	13
5.2	Replacing carbon brushes	14
6	Accessories and consumables	15
6.1	Ordering consumables	15
7	Appendix: Declaration of conformity, guarantee, replacement parts lists	17

1. Safety

1.1 General safety information

WARNING

Read all safety warnings and all instructions.

- Failure to follow the warnings and instructions may result in electric shock, fire and/or serious injury
- Save all warnings and instructions for future reference.

DANGER

Electrical voltage! Risk of fatal injury due to electric shock!

- Remove the plug from the plug socket before undertaking any maintenance work on the machine.
- Check the plug, cable and machine for damage each time before using the machine.
- Keep the machine dry and do not operate it in damp rooms.
- Connect the fault current (FI) circuit breaker with a maximum breaking current of 30 mA when using the electric tool outside.
- Only use original TRUMPF accessories.

WARNING

Damage to the machine due to improper handling.

- Wear safety glasses, hearing protection, breathing protection, protective gloves and working shoes when working.
- Connect the plug only when the machine is switched off. Pull the power plug after use.
- Do not carry the machine by the cable.
- Have maintenance carried out by specialists.

1.2 Specific safety information for seam locker

DANGER

Damage to property due to improper handling!

Machine will be damaged or destroyed.

- Do not carry the machine by its cable.
- Always guide the cable away to the rear and avoid guiding the cable over sharp edges.
- Hand-operated power tools should be repaired and tested by a qualified specialist. Only use original TRUMPF accessories.

 **WARNING****Risk of injury to hands.**

- Do not reach into the processing line with your hands.
- Use both hands to hold the machine.

2. Description



- | | | |
|------------------------------------|-------------------|------------------------|
| 1 On/Off switch | 4 Adjusting screw | 6 Top and bottom blade |
| 2 Chip deflector (hand protection) | 5 Fixing screw | 7 Ram |
| 3 Cutting table | | |

TruTool S 160 shears (2A1)

Fig. 79481

2.1 Intended use



Damage to the machine due to improper handling.

- Only use the machine for work and materials as described under "Intended use."

The TRUMPF TruTool S 160 shears (2A1) is an electrically powered hand-held device designed for the following applications:

- Slitting of plate-shaped workpieces made of steel, aluminum, plastic, etc.
- Slitting of straight and curved exterior and interior cutouts.
- Slitting from scribed lines.

2.2 Technical data



	Other countries			USA
	Values	Values	Values	Values
Voltage	230 V	120 V	110 V	120 V
Frequency	50/60 Hz	50/60 Hz	50/60 Hz	50/60 Hz
Acceptable material thickness				
Steel up to 400 N/mm²	1.6 mm			0.063 in
Steel up to 600 N/mm²	1.2 mm			0.048
Steel up to 800 N/mm²	1.0 mm			0.039
Aluminum up to 250 N/mm²	2.0 mm			0.079
Working Speed	8 - 12 m/min			26- 39 ft/min
Nominal power consumption	350 W			
Idle stroke rate	5800/min	6300/min	6000/min	6300/min
Weight	1.6 kg			3.6 lbs
Smallest radius for curved cut-outs	16 mm			0.59 in
Starting hole diameter	27 mm			1.06 in
Protective insulation	II / 			

Tab. 1

2.3 Icons

Note

The following symbols are important for reading and understanding the operator's manual. The correct interpretation of the symbols will help you operate the machine better and safer.

Icon	Name	Description
 / 	Read operator's manual	Read the operator's manual and safety information in their entirety before starting up the machine. Closely follow the instructions given.
	Safety class II	Indicates a doubly insulated tool.

Icon	Name	Description
	Alternating current	Type or property of current
V	Volt	Voltage
A	Ampere	Current, current input
Hz	Hertz	Frequency (oscillations per second)
W	Watt	Power, power input
mm	Millimeters	Dimensions e.g.: material thickness, chamfer length
in	Inch	Dimensions e.g.: material thickness, chamfer length
n_0	Idle speed	Revolution speed without load
.../min	Revolutions/strokes per minute	Revolution speed, stroke rate per minute

Tab. 2

2.4 Noise and vibration information

WARNING

Noise emission value may be exceeded.

- Wear hearing protection.

WARNING

The vibration emission value can be exceeded!

- Select the right tools and exchange them in time in the event of wear.
- Have maintenance carried out by trained specialized technicians.
- Define additional safety measures for protecting the operator from the effect of vibrations (e. g. keep hands warm, organization of working procedures, machining at normal feed force).
- Depending on the operating conditions and state of the electric tool, the actual load might be higher or lower than the specified measured value.

Notes

- The specified vibration emission value was measured in accordance with a standardized testing procedure and can be used to compare one electric tool with another.
- The specified vibration emission value can also be applied for a provisional estimate of the vibration load.
- Times during which either the machine is switched off or running but not actually in use can considerably reduce the vibration load during the entire working period.

Designation of measured value	Unit	Value according to EN 60745
Vibration emission value a_h (vector sum of three directions)	m/s ²	3.9
Uncertainty K for vibration emission value	m/s ²	1.5
A-class acoustic pressure level L_{PA} typically	dB (A)	77
A-class acoustic power level L_{WA} typically	dB (A)	88
Uncertainty K for noise emission value	CM	3

Tab. 3

3. Setting work

3.1 Selecting blades

NOTICE

Damage to property as a result of incorrect blade selection!
This strongly impairs the cut quality and the individual tools become overstressed.

- Use suitable tools only.

The cutter is characterized by the following points:

- Moving cutter blade (upper blade) and cutting table blade (lower blade) are the same size and can be used (top or bottom) as much as desired.
- All cutters have four blades.
- They are "4-fold multi-edge cutters" which cannot be grinded again.

Notes

- Depending on the sheet thickness or the tensile strength of the workpiece, two different types of blade can be selected for machining.
- Standard configuration blades for sheets with a tensile strength $\leq 400 \text{ N/mm}^2$ do not have any special identification. Chromium steel blades are identified with "Cr".
- For this reason, it is recommended that the tools only be used in accordance with the details mentioned in the table.

Cutter type	Sheet thickness ranges mm	Material type and tensile strength
Standard	0.3 - 2.0	Aluminum 250 N/mm ²
Standard	0.3 - 1.6	Mild steel 400 N/mm ²
Cr	0.3 - 1.2	Stainless steel 600 N/mm ²
Cr	0.3 - 1.0	Stainless steel 800 N/mm ²

Tab. 4

3.2 Setting cutting clearance

The blade clearance is set to a sheet thickness of 1 mm on delivery of the machine. To attain optimum cutting results, set the following values:

Examples:

Sheet thickness mm	Blade clearance = Cutting clear- ance a mm
0.3 - 0.6	0.1
0.8 - 1.2	0.2
1.3 - 1.6	0.3

Values cutting clearance

Tab. 5

1. Tap the on/off switch several times until the moving cutter blade has reached the lower dead point.
2. Loosen lower blade.

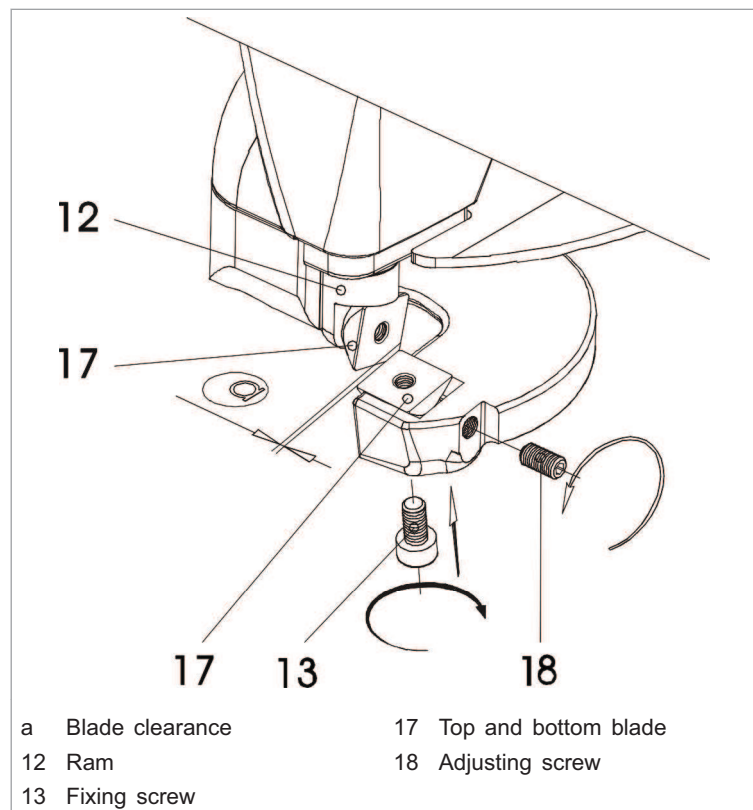

Fig. 24015

3. Using the adjusting screw (18), set the blade to the required clearance a.
4. Retighten blade.
5. Gently tighten the adjusting screw.

6. Check clearance using setting gauge.

4. Operation

CAUTION

Damage to property due to excessively high line voltage!

Motor damage.

- Check the power supply voltage. The power supply voltage must correspond to the information on the nameplate of the machine.

WARNING

Damage to the machine due to improper handling.

- Make sure the machine is always in a stable position when operating it.
- Never touch the tool while the machine is running.
- Always operate the machine away from your body.
- Do not operate the machine above your head.

4.1 Switching TruTool S 160 (2A1) on and off

Switching on the machine

1. Slide the On/Off switch forwards.

Switching off the machine

2. Slide the On/Off switch to the rear.

4.2 Working with TruTool S 160 (2A1)

Cutting radii

- Do not cant machine.
- Work only with low feed.

Cutting at the edge

- Cutting in upside-down position.
- The cutting table faces upwards.

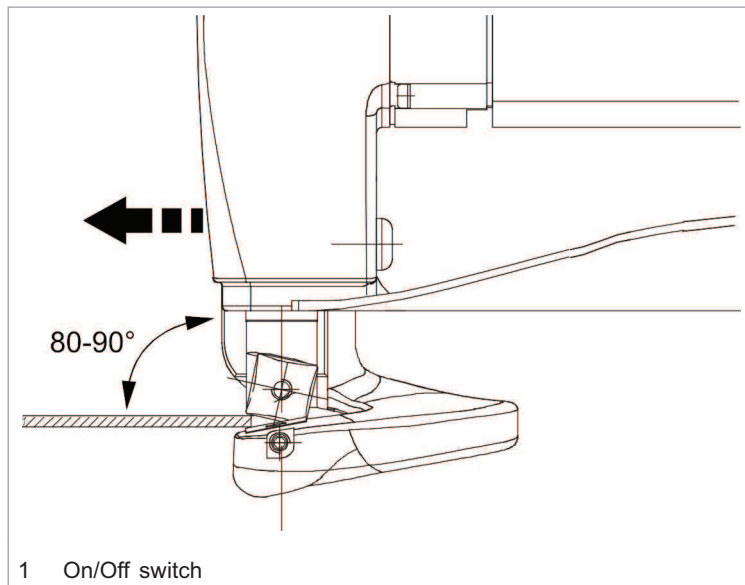

Fig. 24014

1. Do not move the machine towards the workpiece until full speed has been reached.
2. Edit material.
 - Bring device to the sheet surface at an angle of 80 to 90°.

5. Maintenance

⚠ DANGER

Risk of fatal injury due to electric shock!

- Remove the plug from the plug socket before changing the tool or undertaking any maintenance work on the machine.

⚠ WARNING

Risk of injury due to incorrect repair work

Machine does not work properly.

- Maintenance may be carried out by trained specialist technicians only.

⚠ CAUTION

Damage to property caused by blunt tools!

Machine overload.

- Check the cutting edge of the blade hourly for wear. Sharp blades have a good cutting performance and prevent damage to the machine.
- Change blades in a timely manner.

Maintenance point	Procedure and interval	Recommended lubricants
Ram guide	Every 300 operating hours	Lubricating grease "G1"
Gearbox and gear head	After 300 operating hours, arrange for a trained specialist to relubricate or to replace the lubricating grease.	Lubricating grease "G1"
Cutting table blade	Turn if necessary	-
Cutting table blade	Change as needed	-
Moving cutter blade	Turn if necessary	-
Moving cutter blade	Change as needed	-
Ventilation slots	Clean as needed	-
Tooling	Check for wear hourly	-

Maintenance positions and maintenance intervals

Tab. 6

5.1 Changing blade

Top and bottom blades are the same. They both have four cutting edges and are interchangeable. If the cutting performance is not satisfactory, turn each blade by 90° or replace them.

Note

Make sure that the adjusting screw (18) is directly at the bottom blade.

1. Release screw on the respective blade.

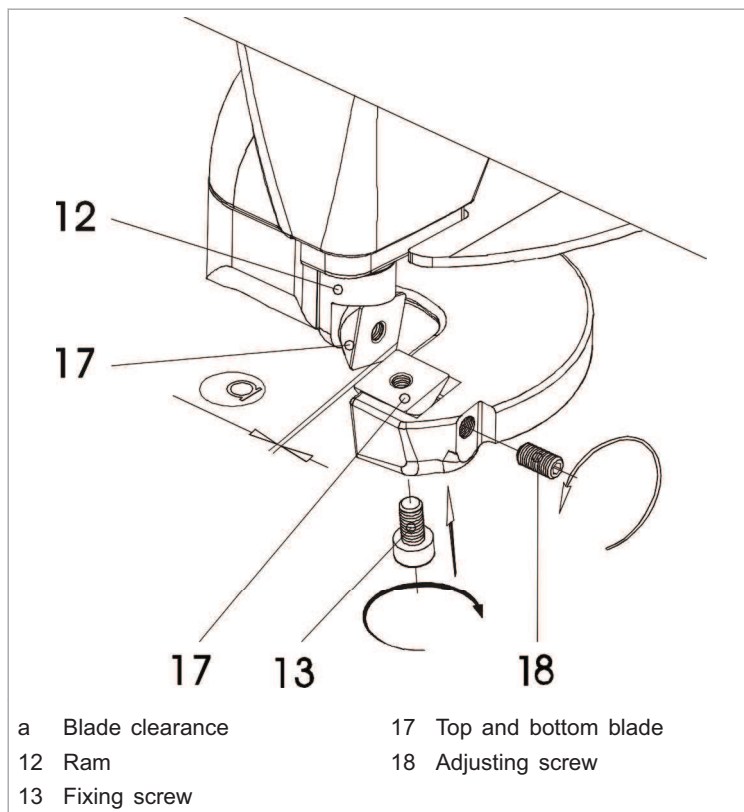

Fig. 24015

2. Turn blade by 90°.
3. Tighten the screws.

5.2 Replacing carbon brushes

The motor comes to a standstill whenever the carbon brushes are worn out.

Notes

- Use only original spare parts from TRUMPF.
 - Observe the information on the rating plate.
- Have the carbon brushes checked and replaced as required by a qualified technician.

6. Accessories and consumables

Note

Moving cutter blade (upper blade) and cutting table blade (lower blade) are the same size and can be used (top or bottom) as much as desired. All cutters have four blades.

They are "4-fold multi-edge cutters" which cannot be grinded again.

Consumables	Order number	Scope of delivery
Cutter, mild steel		
2-pack	0126471	X
10-pack	1264320	-
Blade CR		
2-pack	0919760	-
Cutter, titanium-coated		
2-pack	2089660	-
Lubricating grease "G1" tube (25 g)	0344969	-
Lubricating grease "G5", can (900 g)	1954202	-

Tab. 7

Accessories	Order number	Scope of delivery
Allen key DIN 911-2	002946	x
Allen key DIN 911-3	094840	x
TRUMPF Box S1	1763681	x
TRUMPF Box S101 lining	1771092	x
Operator's manual	2012078	x
Safety notes	0125699	X

Tab. 8

6.1 Ordering consumables

Note

The following data must be specified in order to ensure that parts are delivered correctly and without delay.

1. Specify the order number.
2. Enter further order data:

-
- Voltage data
 - Quantity
 - Machine type
3. Specify the complete shipping information:
- Correct address.
 - Desired delivery type (e.g. air mail, courier, express mail, ordinary freight, parcel post).

Note

For TRUMPF service addresses, see
www.trumpf-powertools.com.

4. Send the order to the TRUMPF representative office.

**7. Appendix: Declaration of conformity,
guarantee, replacement parts lists**

