

# PILOUS ®

## INSTRUCTION MANUAL

ARG 330 S.A.F. • ARG 330 plus S.A.F. • ARG 380 plus S.A.F.  
ARG 400 plus S.A.F. • ARG 500 plus S.A.F.

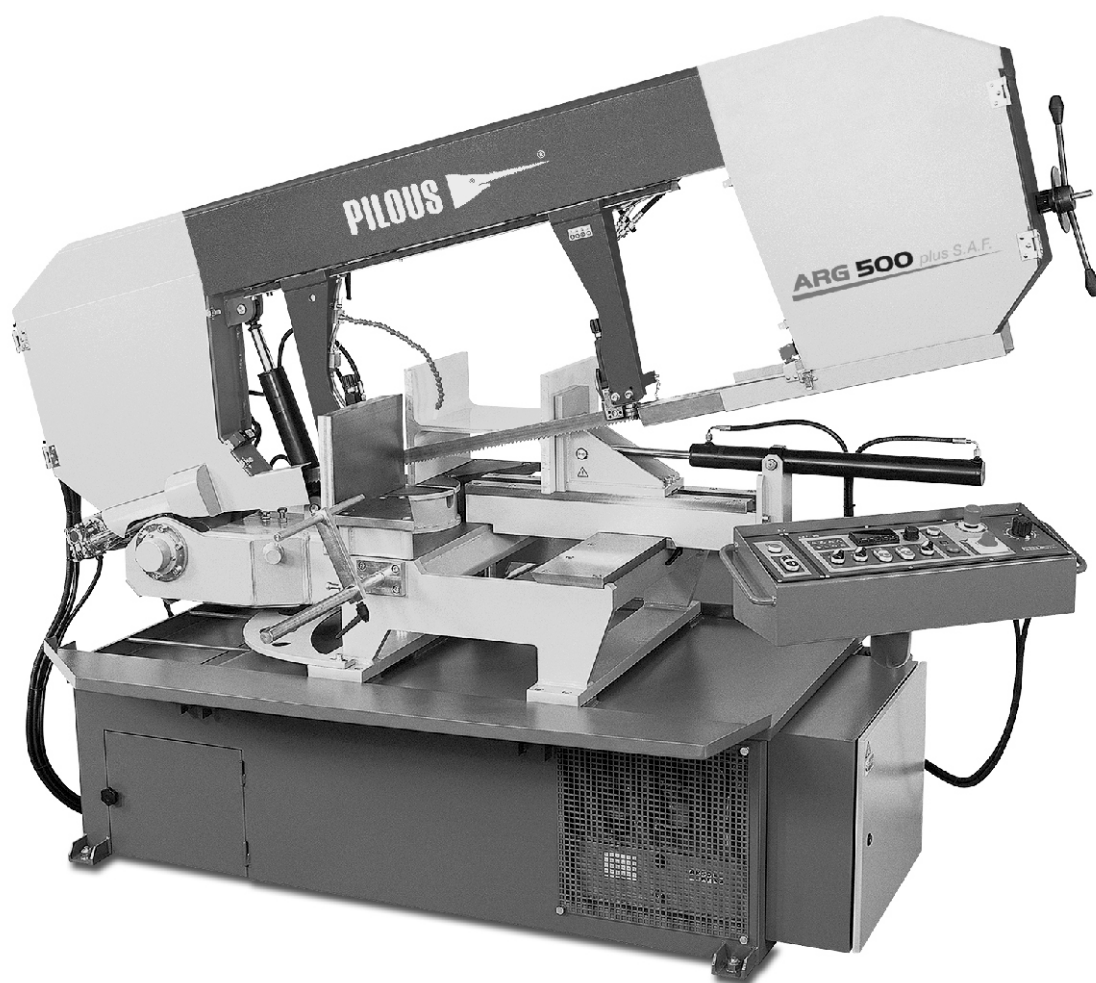

Pilous - pásové pily, spol. s r.o., Železná 9, 619 00 Brno, Czech Republic  
tel.: 00 420 543 252 010, e-mail: pilous@pilous.cz, www.pilous.cz



**Dear customer,**

thank you for purchasing our product. We wish you a lot of success with it in your business. Please pay close attention to the following instructions in order to ensure faultless operation of the machine.

© 2016 All rights, particularly the right to make copies of, to distribute and translate this instruction manual, are reserved. No part of this instruction manual may in any form (printing, copying, microfilm or other means) be reproduced or stored, processed, copied or distributed using electronic systems without a permission by PILOUS.

**Contents:****0. General**

- 0.1. Safety Provisions
- 0.2. Scope of Use / Use According to Designation
- 0.3. Requirements on Operators
- 0.4. Machine Requirements - Safety Devices
- 0.5. Protective Covers

**1. Transport and Storage**

- 1.1. Surface Protection
- 1.2. Packing
- 1.3. Disassembly/Repacking
- 1.4. Disposal

**2. Technical Data****3. Installation**

- 3.1. Space Requirements
- 3.2. Removal of Temporary Transport Beams and Fixation of the Machine
- 3.3. Machine Installation
- 3.4. Connection to the Mains
- 3.5. Arm release in ARG 380, 400, 500 plus S.A.F.

**4. Machine Description**

- 4.1. Control Panel
- 4.2. Control Valve - Saw Blade Feed to the Cut
- 4.3. Saw Blade Feed Pressure Control
- 4.4. Vice
  - 4.4.1. Adjustment of the Lateral Play of the Vice in ARG 330 S.A.F. and ARG 330 plus S.A.F.
  - 4.4.2. Cutting Angle Settings
- 4.5. Arm - saw blade guidance
- 4.6. Removal of Protective Housing
  - 4.6.1. Removal of Protective Housing of the Saw Blade Arm ARG 330 S.A.F., ARG 330 plus S.A.F., ARG 400 plus S.A.F.
  - 4.6.2. Removal of Protective Housing of the Saw Blade Arm ARG 380, 500 plus S.A.F..
- 4.7. Replacement, Tensioning and Adjustment of the Saw Blade
- 4.8. Guide Heads - Adjustment
- 4.9. Hydraulic Unit
  - 4.9.1. Vice Clamping Force Setting
- 4.10. Cooling System

**5. Commissioning**

- 5.1. Security Check
- 5.2. Cutting Procedure

**6. Machine Maintenance**

- 6.1. Cleaning
- 6.2. Removal/disposal of chips
- 6.3. Coolant system cleaning
- 6.4. Lubrication
  - 6.4.1. Lubrication Plan for ARG 330 S.A.F., ARG 330 plus S.A.F.
  - 6.4.2. Lubrication Plan for ARG 400 plus S.A.F.
  - 6.4.3. Lubrication Plan for ARG 380, 500 plus S.A.F.
- 6.5. Principles of Hydraulic Unit Maintenance
  - 6.5.1. Work safety
  - 6.5.2. Commissioning
  - 6.5.3. Hydraulic Liquids
  - 6.5.4. Hydraulic Mineral Oils
  - 6.5.5. Service intervals
  - 6.5.6. Oil Refill and Filter Replacement

**7. Faults and Remedies**

- 7.1. Repairs
- 7.2. Failures - Potential Causes and Remedies

**8. Saw Blades**

- 8.1. Saw Blade Design
- 8.2. Selection of Tooth Size
- 8.3. Optimum Workpiece Clamping
- 8.4. Running-in New Saw Blades
- 8.5. Factors Influencing Saw Blade Service Life
- 8.6. Values Recommended for Cutting

**9. Nameplate****10. Electrical Wiring Diagram****11. Hydraulic Unit Wiring Diagram**

- 11.1. Hydraulic Unit Wiring Diagram ARG 330 S.A.F., ARG 330 plus S.A.F., ARG 400 plus S.A.F.
- 11.2. Hydraulic Unit Wiring Diagram ARG 380, 500 plus S.A.F.

**12. Accessories**

- 12.1. Laser Guideline Light
  - 12.1.1. Activation and deactivation of the laser beam
  - 12.1.2. Laser indication on the machine
  - 12.1.3. Adjustment
- 12.2. Oil Mist Lubrication
- 12.3. Vertical vice for HVP bundle cutting

## 0. General

This instruction manual provides the user with assistance and information about the PILOUS metal-cutting band saw and the possibilities of use corresponding to its purpose. The instruction manual contains important instructions on a safe, adequate and economically efficient operation. Observing the operating instructions will prevent risks; the repair and outage time costs will be reduced and the machine reliability and life increased. The instruction manual contains instructions based on the valid national safety regulations and environmental standards. The instruction manual must be always available at the machine site. The instruction manual must be read and used by the staff entrusted with the machine installation, transport and storage, use / operation, maintenance and disposal. In addition to the instruction manual and binding safety regulations in force in the user's country and at the service site, it is also necessary to observe the approved rules for safe and professional work.

### Letter of Guarantee - Service

The Letter of Guarantee is a separate annex to the instruction manual.

**Guarantee Period** - see Letter of Guarantee

Conditions for Maintenance of Claims under Guarantee

- Transport and storage of the machine in accordance with the instruction manual.
- Use and operation of the machine in accordance with the instruction manual.
- Connection of the machine to the power supply in accordance with the instruction manual.

### The guarantee does not apply to:

- Violent and mechanical damage of the machine caused by interference of the user or other persons.
- Inevitable events (natural disaster).
- Damage to the machine during transport.
- Storage or installation of the machine in humid, chemical or any other inappropriate environment.
- Wear parts (see the Letter of Guarantee).

**Potential claims concerning guarantee and after-guarantee repairs should be made by phone, post or e-mail to the address: see the Letter of Guarantee.**

### Note for the User:

The Seller is obliged to hand over to the User the Letter of Guarantee immediately with the purchase of the product. The Letter of Guarantee must be properly and legibly filled out and confirmed by the Seller's stamp, signature and date of purchase. The Seller is obliged to inform the Buyer about the use and handling of the product.

### Data Necessary for Claiming Guarantee (After-Guarantee) Repair:

- Machine type
- Letter of Guarantee Number (identical with the serial number of the machine)
- Date of issue of the Letter of Guarantee

## 0.1. Safety Provisions

The machine design complies with the technical status and the approved safety and technical rules. In spite of this, the user's or the third persons' health can be endangered and/or the machine or other tangible goods may be unfavorably influenced during the operation of the machine. In order to prevent such hazards, it is absolutely necessary to observe the safety instructions in this instruction manual. These safety instructions must be read and understood by the respective persons before the machine has been put into operation. Failure to observe these instructions may lead to serious health and property damage! The safety instructions in this instruction manual are marked with safety symbols / danger spot signs.



**Warning: Dangerous spot -  
Use the highest caution!**



**Caution: Dangerous voltage!**



**Use protective goggles!**



**Health hazard by flying particles!**



**Use hearing protection!**



**Danger of injury by compression!**



**Use boots or work shoes with a steel toe.  
And with anti-slide soles.**



**Danger of injury by cutting!**



**Use protective gloves!**



**Before using the bandsaw, read this instruction manual carefully and make sure you understand its content!**



## 0.2. Scope of Use / Use According to Designation

The machine is intended solely for cutting (primarily metal) workpieces. Any other use is considered as inadequate to the purpose. The manufacturer is not responsible for damages arising from such use, the risk is borne by the user alone. The use complying with the purpose includes also observing the operating instructions and the check and maintenance conditions.

**Examples of materials that can be cut:** structural steel • cementing steel • nitriding steel • free-cutting steel • heat-treated steel • roller bearing steel • spring steel • tool steel • high-speed steel • cast steel • cast iron • copper • brass • aluminium • plastics.

Consider the recommendations for use as prescriptive values. In case of special cases, consult the manufacturer.

## 0.3. Requirements on operators

**The machine may only be operated by persons that have been appropriately trained and instructed in safety at work!**

The machine may only be operated if it is in perfect condition with respect to technical safety. The user is obliged to check the machine for visually detectable damages and faults at least once per shift. Immediately report to your manager any damages and faults on protective devices and changes in the operation of the machine that threaten safety. No safety devices may be removed, moved, put out of operation or changed during the machine operation. Otherwise any warranty claims shall be null and void! If any safety device has to be removed during operation or maintenance, secure the MAIN SWITCH in the „OFF" position by a padlock or disconnect the machine from the mains and secure it against restart.

- Remove loose parts of clothes, cover long hair.
- Make sure that all other persons stand or move at least 2 meters from the saw blade, protect them from flying chips and prevent harm to them in case the saw blade breaks.
- All persons helping you at the site must be made familiar with all the safety rules.
- The safety rules must be provided on a visible place at the site.
- Keep hands at a safe distance from the saw blade; never adjust the device when the motor is running. Switch off the motor and secure it against restart before you start handling the saw blade.



**Only persons with adequate electrician qualifications are allowed to open protective covers of the electrical equipment and to work on it.**

## 0.4. Machine requirements - Safety devices

### Danger of Injury!



**No cover on the saw blade in the cutting area! High risk of injury in the operating area of the arm!  
Before you open protective devices, wait until the saw blade and the grinding wheel stop.  
Never use the sharpener when you are tired, exhausted, under the influence of medicaments, drugs or alcohol!**

Horizontal metal band saw is a cutting machine equipped for saw blade cutting. In order to complete the manufacturing process the grinding wheel must reach the saw blade in the machining area. You can install the protective covers against contact with the saw blade only outside the machining area.

## 0.5. Protective covers

The saw blade and its wheels are protected against contact outside the machining area. You can remove protective covers only if the MAIN SWITCH is turned off and secured against restart or if the machine is disconnected from the mains and the saw blade is still. Before leaving the band saw, all covers must be closed. The protective cover of the arm and wheels with the saw blade are secured by an end switch. If the covers are not completely closed, none of the machine's drives will start.

To stop the machine in case of emergency, press **TOTAL STOP** button. You can put the machine back to operation only after you manually unlock the switch by turning it clockwise. Fixed and movable bars of guide heads are fitted with solid protective covers that protect the area outside the machining area.



**Manual cleaning and removal of waste when the machine is working or running down is prohibited. A first-aid kit must be available at the workplace. You have to wear suitable work clothes, shoes and adequate protective equipment (eye protection, hearing protection, gloves, steel-toed work shoes) at work. Observe valid health rules concerning the air quality at the workplace.**

## 1. Transport and Storage

You can transport and lift the machine only with a forklift. In ARG 330 S.A.F, ARG 330 plus S.A.F. slide the forks under the machine base from the back to prevent damage; see the picture. In ARG 380, 400, 500 plus S.A.F. it is possible to slide the forks also from the side. When handling the machine with a forklift, always make sure that the machine is balanced on the forks.

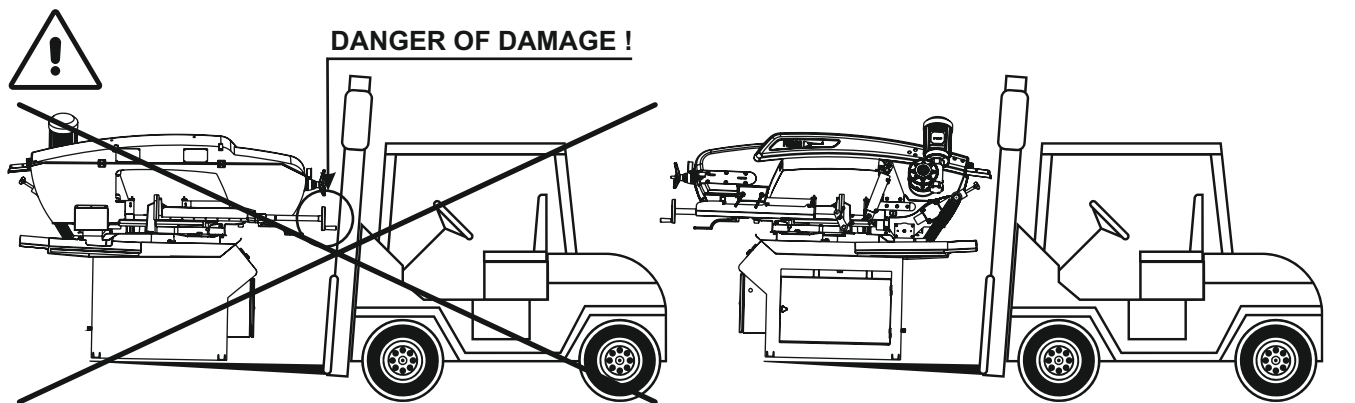

**You can transport and lift the machine only with a forklift. THE USE OF A CRANE PROHIBITED!**

### 1.1. Surface Protection

Machine parts are protected against corrosion by powder coating or a primer and two-component polyurethane varnish. Sliding surfaces are coated with anti-corrosive oil. Surfaces of other parts and components of the machine are treated by galvanization or blackening.

### 1.2. Packing

The machine is supported on wooden beams, which provide a space of approximately 100mm from the ground for the purpose of the transport and loading with a forklift. The machine is packed in a stretching foil that protects it against weather influence during transport.

#### Standard accessories:

- 1 pc. metal saw blade, bimetal M42 (mounted),
- 1 pc. band saw instruction manual
- 1 pc. length stop - only ARG 330 S.A.F., ARG 330 plus S.A.F..

### 1.3. Disassembly / Repacking

Disconnect the machine from the mains • empty and clean the metal chip tank and the coolant tank • clean the machine • apply anticorrosive oil on the sliding surfaces • before the transport, unscrew the filling cap from the hydraulic unit and replace it with a transport cap, see section 4.9. • fix the arm for transport see section 3.5. • lift the machine and place it on beams • observe the distance of approximately 100 mm from the ground for the transport with the forklift • make sure that all protective covers of the machine are in place and fastened • add the machine accessories



**Caution: used coolants belong to the category of special waste!**

**Only a person with adequate electrician qualifications can disconnect the machine from the mains!**

### 1.4. Disposal













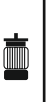
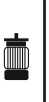
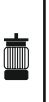

















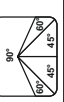

When the machine has been definitely put out of operation, it should be disposed of in accordance with the provisions valid in the respective country. We recommend that you contact a specialist waste disposal service.

## 2. Technical data

**Machine noise** - measured in conformity with ČSN EN ISO 3746:2011

The acoustic pressure level at the workplace: 76 dB (A), acoustic power level: 91 dB (A).

The measured values exceed the value specified in the Government Regulation No. 176/2008, section 1.7.4.2, article u) and therefore ear protection must be used during the machine operation. The measurement was carried out while the machine was in a steady state and the saw blade speed was 80m/min. During the operational state with a technical load, the most frequently used technological process was measured. Noise levels measured on the machines may vary depending on the type of cut material, saw blade speed and other factors.

		ARG 330 S.A.F.	ARG 330 plus S.A.F.	ARG 380 plus S.A.F.	ARG 400 plus S.A.F.	ARG 500 plus S.A.F.
MAIN MOTOR		400 V, 50 Hz 3,0 kW	400 V, 50 Hz 3,0 kW	400 V, 50 Hz 3,0 kW	400 V, 50 Hz 3,0 kW	400 V, 50 Hz 4,0 kW
PUMP MOTOR		400 V, 50 Hz 0,12 kW	400 V, 50 Hz 0,12 kW	400 V, 50 Hz 0,12 kW	400 V, 50 Hz 0,12 kW	400 V, 50 Hz 0,12 kW
BRUSH MOTOR		400 V, 50 Hz 90 W	400 V, 50 Hz 90 W	400 V, 50 Hz 90 W	400 V, 50 Hz 90 W	400 V, 50 Hz 90 W
HYDRAULIC UNIT MOTOR		400 V, 50 Hz 550 W	400 V, 50 Hz 550 W	400 V, 50 Hz 550 W	400 V, 50 Hz 550 W	400 V, 50 Hz 550 W
SAW BLADE SPEED		15 - 90 m/min	15 - 90 m/min	15 - 90 m/min	15 - 90 m/min	15 - 90 m/min
CUTTING ANGLE RANGES	[mm]	 90°	 90°	 90°	 90°	 90°
	∅	 45°	 45°	 45°	 45°	 45°
	a	 60°	 60°	 60°	 60°	 60°
	a x b	 90°	 90°	 90°	 90°	 90°
ARM SWING		3870x34x1,1	3870x34x1,1	4950x34x1,1	4300x34x1,1	6040x41x1,3
SAW BLADE SIZE		420 mm	420 mm	420 mm	500 mm	540 mm
SAW BLADE WHEELS DIAMETER		420 mm	420 mm	420 mm	420 mm	540 mm
SAW BLADE TILT		0°	0°	5°	0°	5°
VICE OPERATING HEIGHT		940 mm	945 mm	860 mm	795 mm	870 mm
OIL IN THE HYDRAULICS		Hydraulic oil Olea OPTIMA HV 46	Hydraulic oil Olea OPTIMA HV 46	Hydraulic oil Olea OPTIMA HV 46	Hydraulic oil Olea OPTIMA HV 46	Hydraulic oil Olea OPTIMA HV 46
COOLANT TANK		approximately 35 litres	approximately 35 litres	approximately 35 litres	approximately 35 litres	approximately 35 litres
MACHINE WEIGHT		665 kg	720 kg	1025 kg	1350 kg	1530 kg

### 3. Installation

#### 3.1. Space requirements

You can install the machine on any suitable and even floor (concrete) in a factory hall. Observe the allowed floor load. The machine should be aligned using the underlay sheets under the base anchors (not included in the shipment).

While preparing the cutting, the operating staff is allowed to move around the machine only when the machine is not running. When the machine is running, the operator has to stay only at the control panel so that he/she is able to switch off the machine any time. The operator must also ensure that no other persons are present in or near the working area of the machine. No unauthorised personnel in the hazard space. To prevent injury, the danger zone must also be level and free from any foreign objects and obstacles.

#### Recommendations / requirements:

- Allow for sufficient space for the feeding and removal of the workpiece and the machine maintenance - the operator's working area should be delineated at 1 m minimum around the machine and 0.5 m around the roller conveyors.
- In order to ensure safe handling of workpieces and protection of the space behind the cut from falling cut-off pieces, one or more roller conveyors must be installed, possibly a container for falling cut workpieces.
- Install a lift mechanism for heavy workpieces.
- Ensure proper lighting at the workplace.

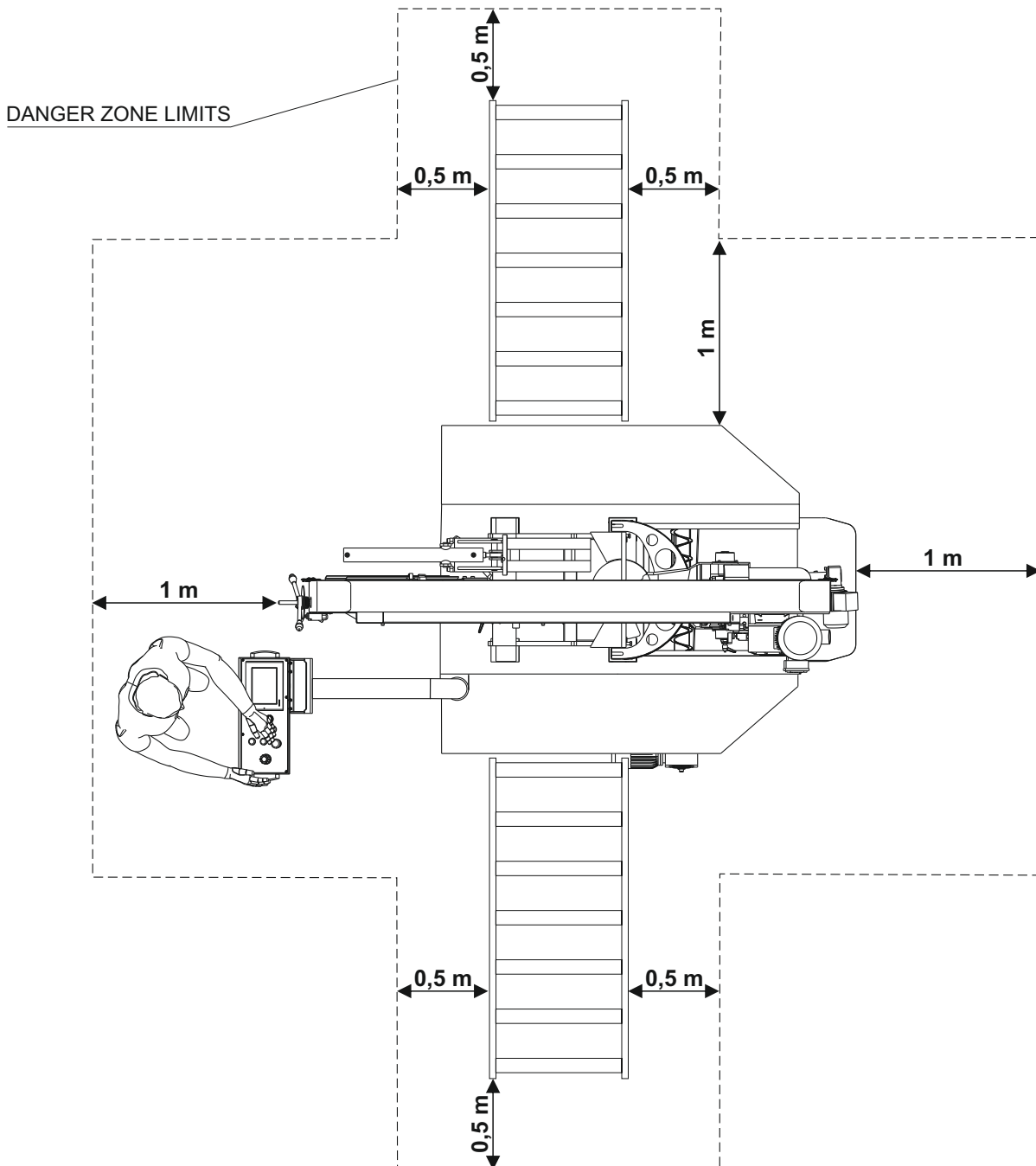

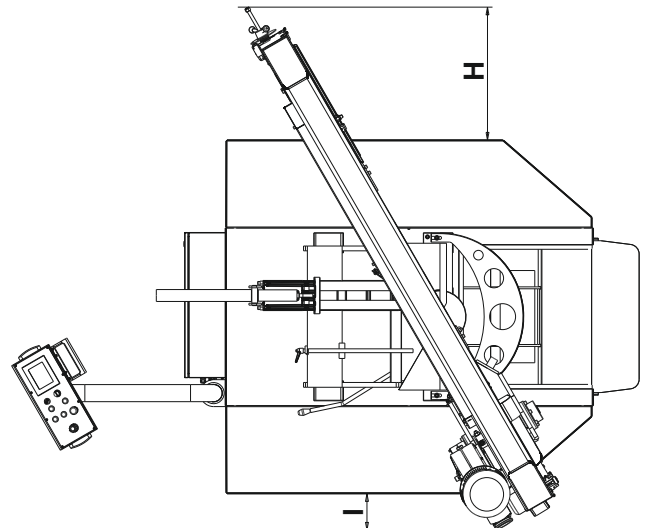
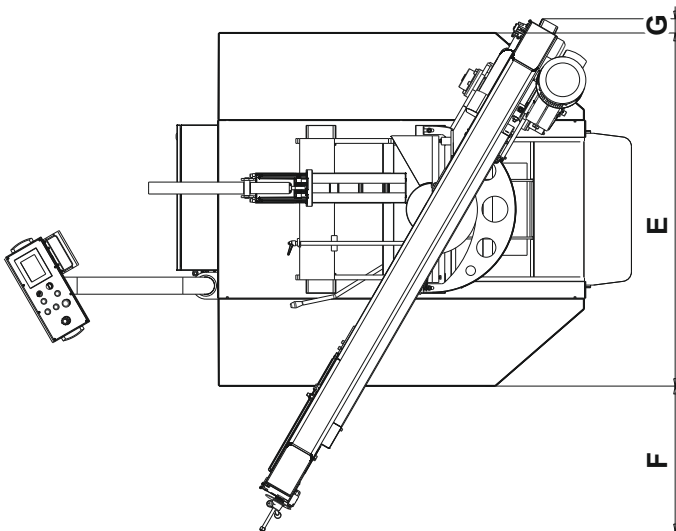
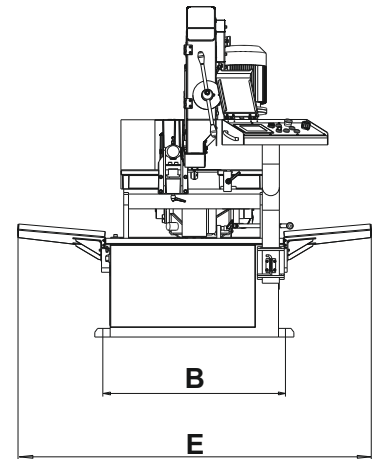
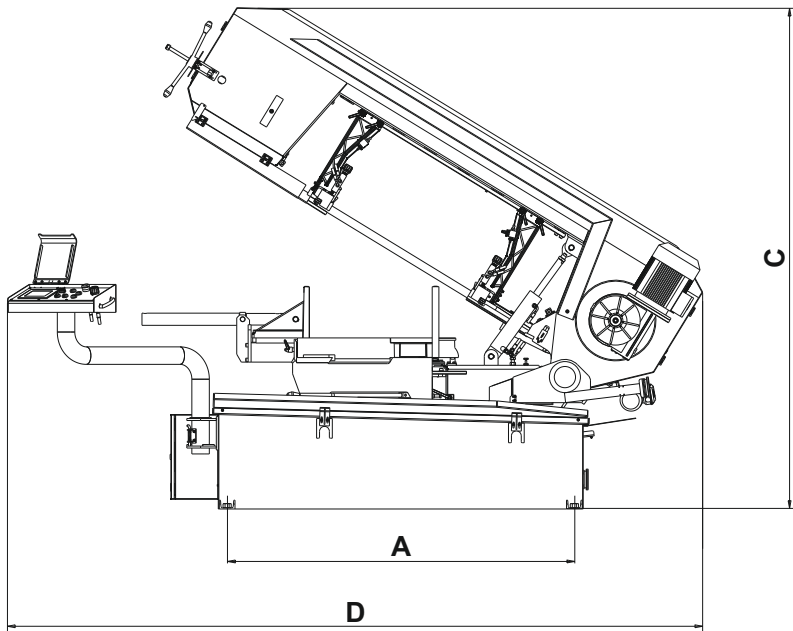

	ARG 330 S.A.F.	ARG 330 plus S.A.F.	ARG 380 plus S.A.F.	ARG 400 plus S.A.F.	ARG 500 plus S.A.F.
A	850	1366	1240	1345	1765
B	945	1040	835	1330	956
C min	1660	1690	1450	1580	1720
C max	2060	2050	2310	2140	2610
D min	2290	2380	2650	2370	3450
D max	2660	2850	3150	2370	3630
E	1360	1870	1520	1305	1845
F	400	540	690	490	760
G	280	250	80	110	350
H	x	250	630	280	380
I	x	400	240	90	370

C min - the arm is lowered  
C max - the arm is raised

D min - the arm is lowered, the vice is closed  
D max - the arm is raised, the vice is opened

### 3.2. Removal of temporary transport beams and fixation of the machine

Use a pallet truck to lift the machine and place it directly on the desired location in the workplace. Unscrew the bolts that hold the machine in place and remove the transport beams. Lift the machine with a crane, remove the beams and lower the machine onto the floor. Level the machine by laying metal sheets under its legs, possibly anchor to the floor. Remove the anticorrosion film and dust from sliding surfaces and apply oil. Ensure connection to the mains (see section 3.4.). Pour the coolant (maximum 30 litres) into the tank; the fluid will gradually flow into the container in the base. The hydraulic unit is fitted with two filling holes that are covered by red transport caps during the transport (see section 6.5.). The cap that is more accessible to the operator has to be removed and replaced by a filling cap, otherwise a risk of making the entire system inoperable arises, along with the risk of pump damage.



**When handling coolants, risks linked to hazardous substances cannot be avoided. Observe the national norms and recommendations/manufacturer's or your company's operating instructions related to safe handling of coolants.**

### 3.3. Machine installation



**Protect the machine against humidity, rain and dust!**

The machine may be operated in the ambient temperature between + 5° and + 40°C. The average air temperature must not exceed + 35°C within 24 hours.

+ 35°C. In temperatures below + 5°C the conventional coolants should be replaced by coolants designed for such temperatures. In addition to that, replace the oil in the hydraulic unit for a less viscous one.

### 3.4. Connection to the mains



**Such operations must be carried out only by persons with electrician qualifications!**

Make sure that the grid voltage, the voltage protection and the connection voltage comply with the power requirements specified in the point 2. Technical parameters. Only current protection of S characteristics can be installed (for a frequency converter). When connecting the machine to the mains (3 NPe 50 Hz, 400 V, TN-S), **mind the colour coding of wires carefully: L1 brown, L2 black, L3 grey, N blue, PE yellow-green. Improper connection of the neutral or PE wires may lead to damage of the electrical equipment or to an electric shock!** Connect the power cable to a protected **16 A** socket, in case of direct connection to the mains it is necessary to fit the supply with a lockable MAIN SWITCH. If the motor rotates in an incorrect direction, swap the conductors **L1** brown and **L2** black on the machine junction box.



**Failure to observe the aforementioned may lead to incorrect rotation of the bandsaw and the coolant pump. Danger: Damage to the machine!**

### 3.5. Arm release in ARG 380, 400, 500 plus S.A.F.

The arm is secured against movement for transport. Demount the yellow console by unscrewing the screws/helix in order to release the arm. In ARG 400 plus S.A.F. unscrew also the clamp and the handle of the console and fasten it into the hole of the helix. In case of transport, secure the arm against movement the same way.

**ARG 400 plus S.A.F.**

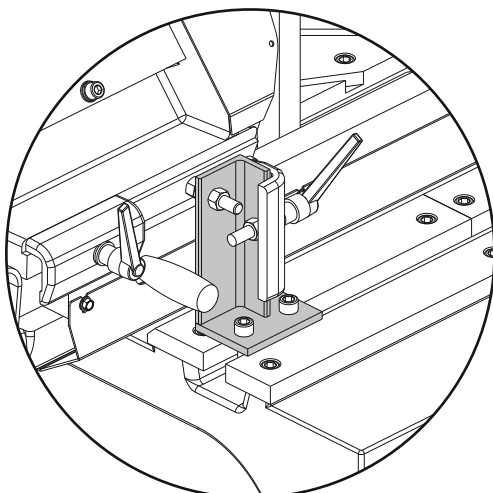

**ARG 380 plus S.A.F., ARG 500 plus S.A.F.**

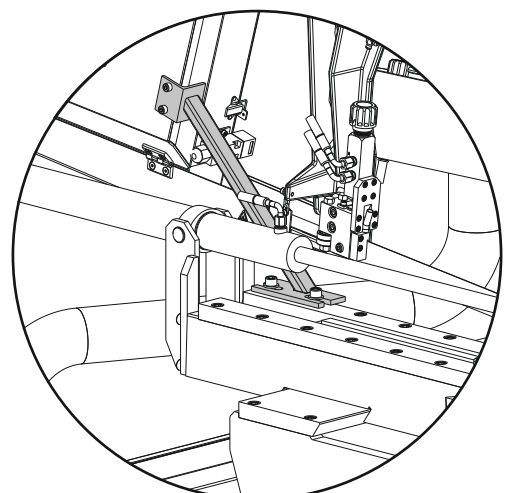

## 4. Machine Description

Horizontal metal-cutting band saws allow for cutting of a wide range of different materials. Pressing a single switch will execute the complete cutting cycle - workpiece clamping, saw blade start, cutting, saw blade stop, arm uplift to the upper (adjustable) position and vice unclamping. In connection with the hydraulic feed of the saw blade into the cut, these measures significantly increase cutting productivity, particularly as regards solid materials. All functions can be controlled separately. The feed of the workpiece is manual. The vice pressure control is included in the basic version of the machine. As the cutting tool, a welded saw blade is used, which is tensioned mechanically via a blade wheel. The saw blade is driven by the blade wheel, which is driven by a single-speed motor via a worm-gear unit (conical face gearbox in the version of ARG 500 plus S.A.F. with optional accessories). In the machining zone, the saw blade is guided through the saw blade guide heads. Outside the machining zone the saw blade is protected by moving and fixed guards. The standard equipment of these machines includes a frequency converter which enables a continuous saw blade speed control within the range of 15-90 m/min. The optimum setting of the saw blade speed substantially increases the productivity of the machine, cutting accuracy and the saw blade service life.

<b>A</b> hydraulic unit	<b>H</b> turntable	<b>N</b> hydraulic cylinder of the vice
<b>B</b> saw blade	<b>I</b> base	<b>O</b> hydraulic stroke cylinder
<b>C</b> saw blade tensioning	<b>J</b> coolant tank with pump	<b>P</b> fixed bar
<b>D</b> gearbox	<b>K</b> control panel	<b>Q</b> movable bar
<b>E</b> motor	<b>L</b> angular scale	<b>R</b> movable bar clamping lever
<b>F</b> vice	<b>M</b> arm swing locking lever	<b>S</b> switchboard
<b>G</b> arm		

**ARG 330 S.A.F.**

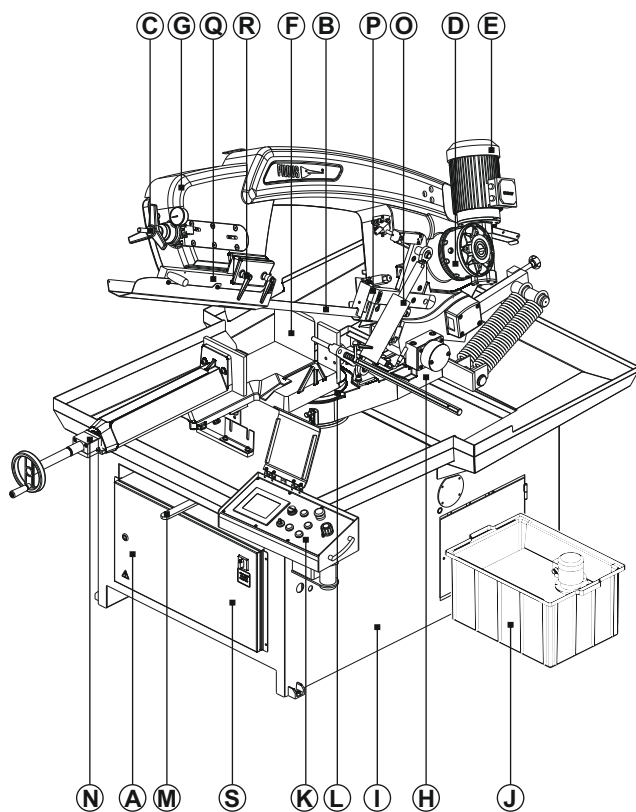

**ARG 330 plus S.A.F.**

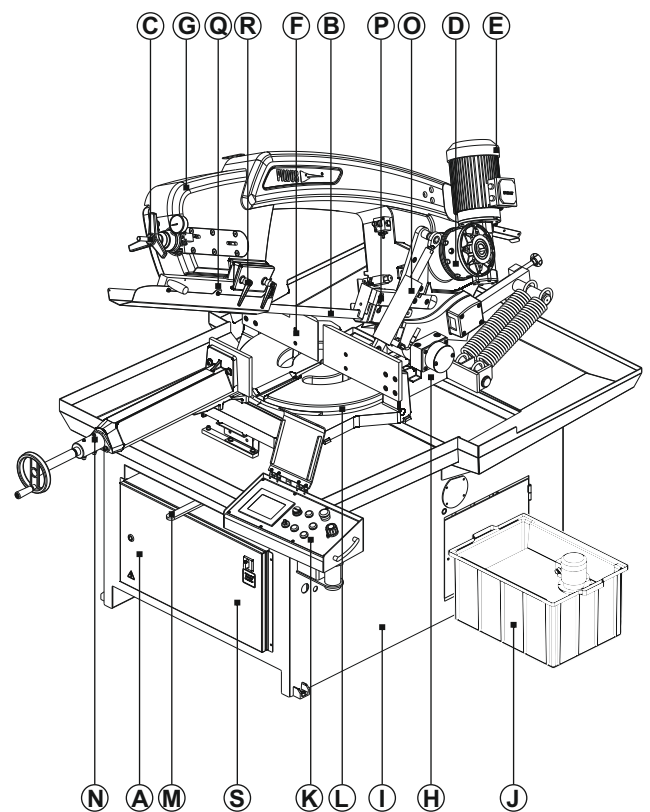



- |                               |                                  |   |
|-------------------------------|----------------------------------|---|
| <b>A</b> hydraulic unit       | <b>H</b> turntable               | <b>N</b> hydraulic cylinder of the vice |
| <b>B</b> saw blade            | <b>I</b> base                    | <b>O</b> hydraulic stroke cylinder      |
| <b>C</b> saw blade tensioning | <b>J</b> coolant tank with pump  | <b>P</b> fixed bar                      |
| <b>D</b> gearbox              | <b>K</b> control panel           | <b>Q</b> movable bar                    |
| <b>E</b> motor                | <b>L</b> angular scale           | <b>R</b> movable bar clamping lever     |
| <b>F</b> vice                 | <b>M</b> arm swing locking lever | <b>S</b> switchboard                    |
| <b>G</b> arm                  |                                  |   |

### ARG 400 Plus S.A.F.

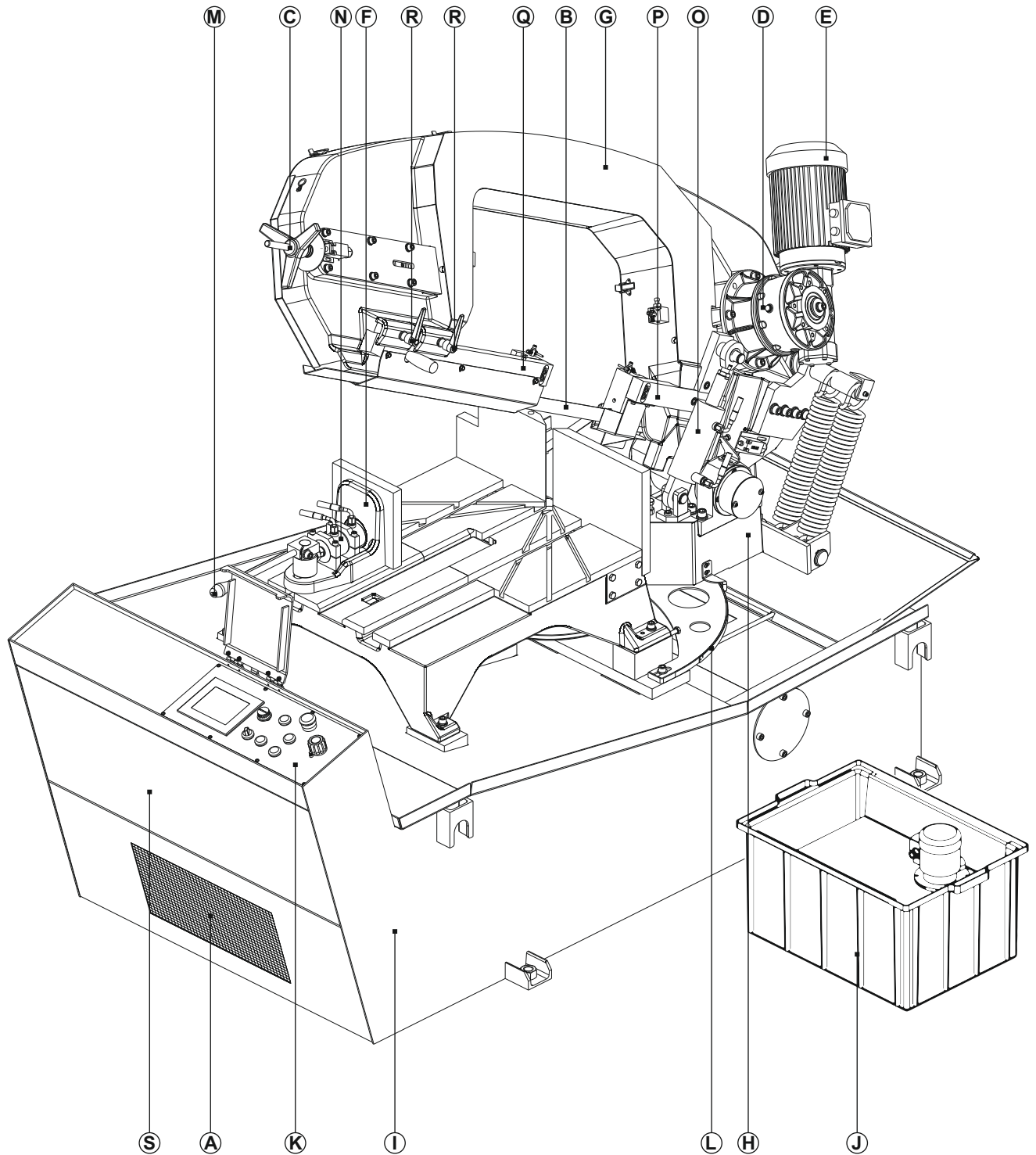

A hydraulic unit  
 B saw blade  
 C saw blade tensioning  
 D gearbox  
 E motor  
 F vice  
 G arm

H turntable  
 I base  
 J coolant tank with pump  
 K control panel  
 L angular scale  
 M arm swing locking lever

N hydraulic cylinder of the vice  
 O hydraulic stroke cylinder  
 P fixed bar  
 Q movable bar  
 R movable bar clamping lever  
 S switchboard

**ARG 380, 500 plus S.A.F.**

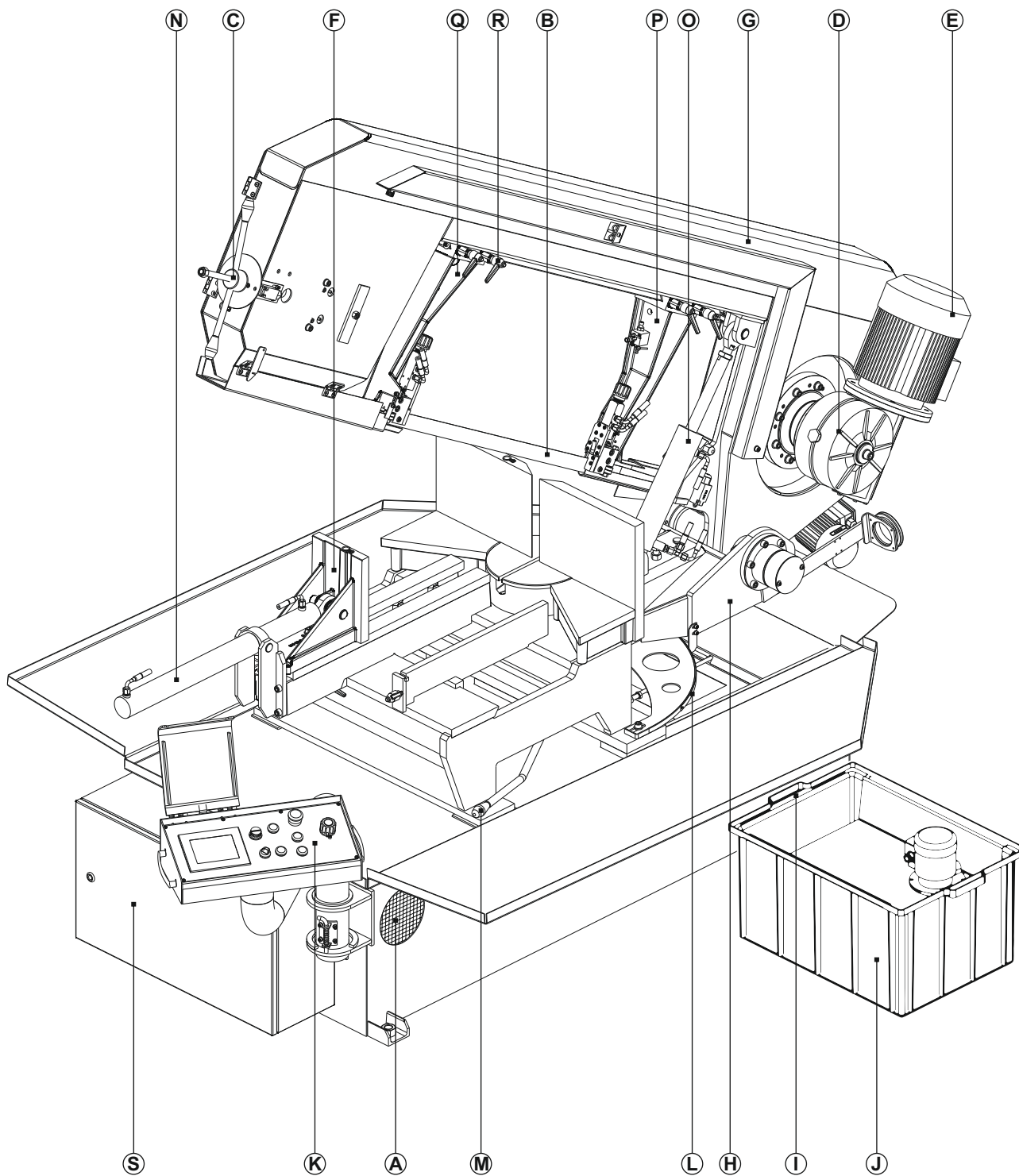

# 4.1. Control panel

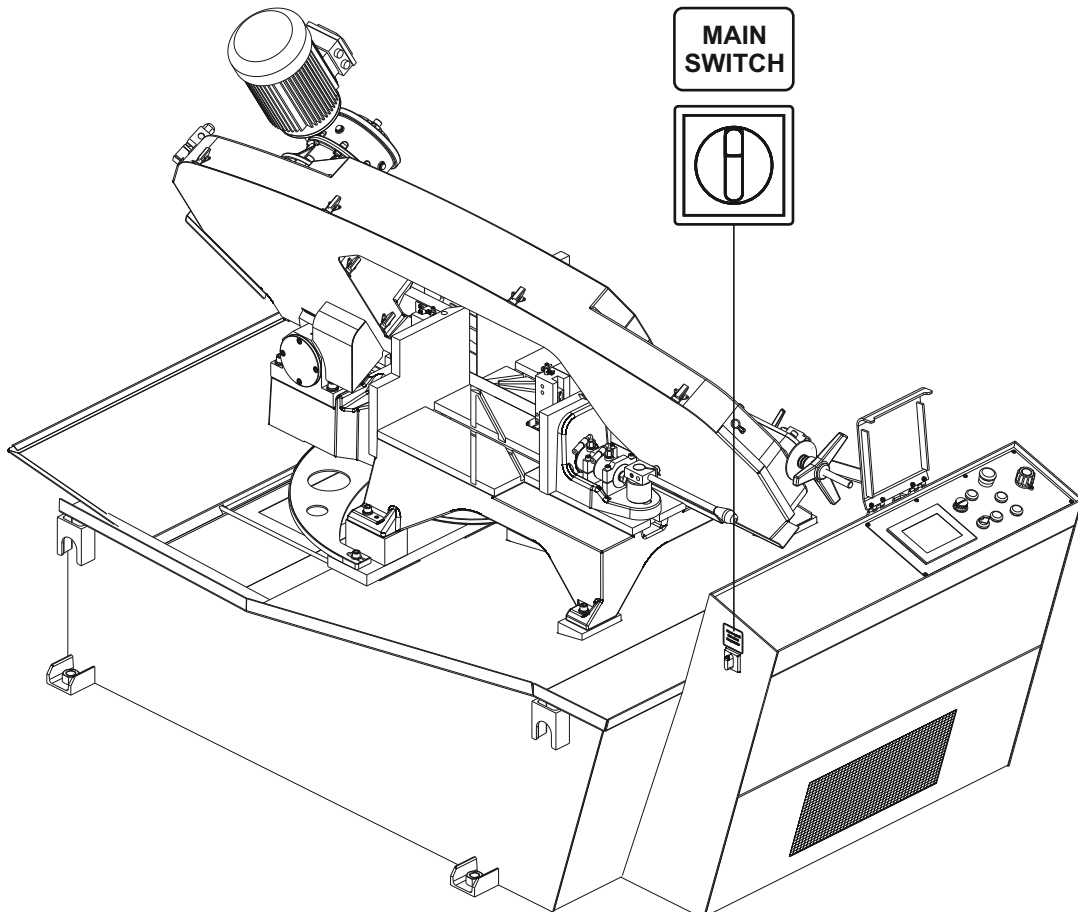
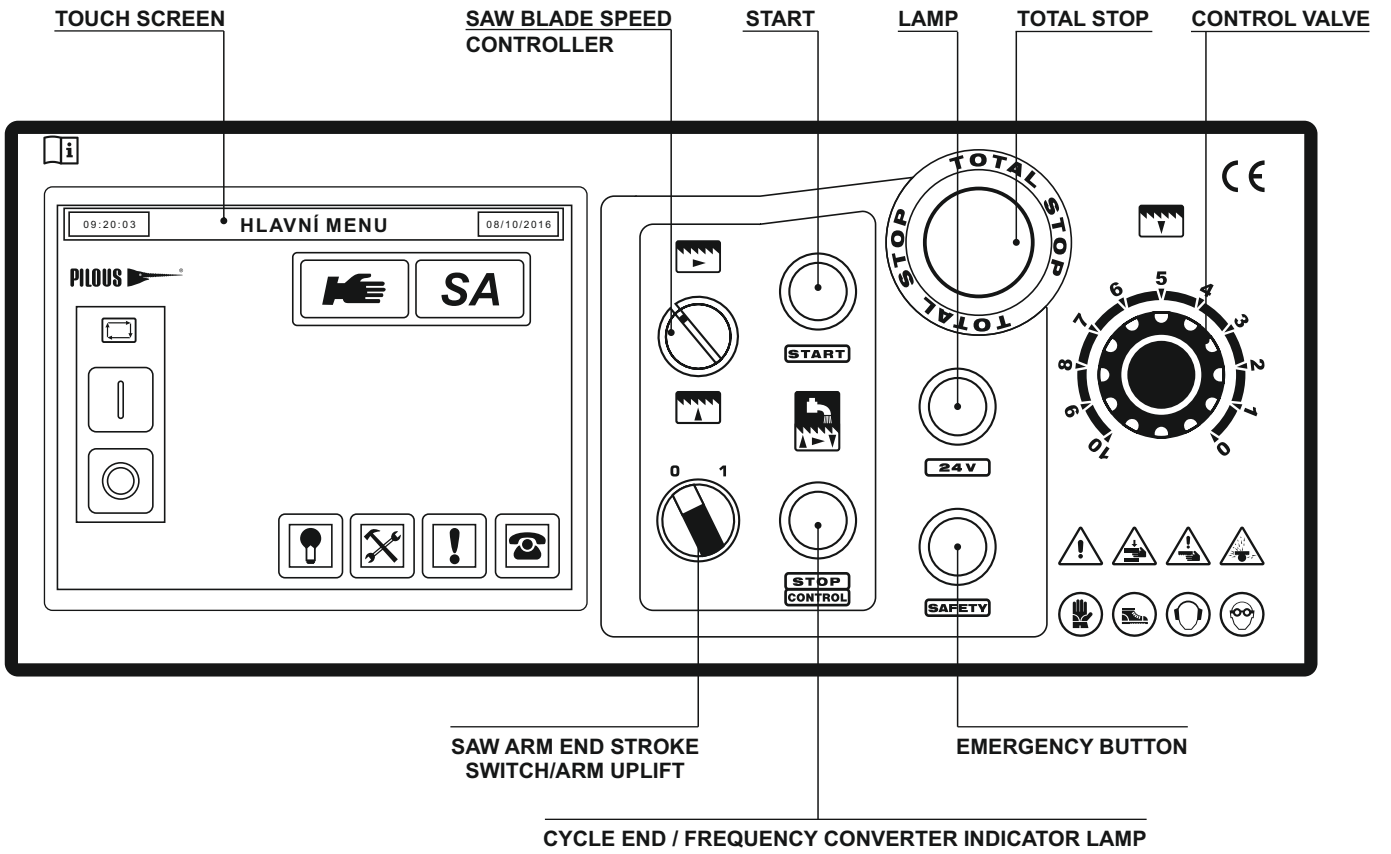

## MAIN SWITCH

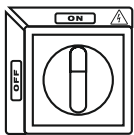

**ON** On

**OFF** Off



Before you start the saw blade motor, always make sure that the saw blade is not in contact with the workpiece at the point of cutting.

## TOTAL STOP

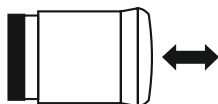

Use for emergency stop of the saw blade motor, coolant pump and hydraulic unit motor (i.e. the whole machine). You can put the machine back to operation only after you manually unlock the switch by pulling or twisting!

## SAW ARM END STROKE SWITCH



MANUAL MODE: position 0 - controls the arm only by the touch screen (up and down); position 1 - arm uplift independent of the touch screen.

S.A. MODE: after the finishing cut the arm remains in the lower position - position 0, or travels to the adjustable upper position - position 1.

Note 1: when transferring from the MANUAL to S.A. MODE (not during cutting) and by turning the switch from 0->1 the machine will not respond, because the S.A. MODE uses the height specified in the MANUAL MODE. In order to lift the arm, you have to edit the arm uplift height afterwards.

Note 2: when transferring from the S.A. MODE into the MANUAL MODE (not during cutting), while the switch is in position 1, the arm will travel upwards only after you switch from 0->1 again.

## EMERGENCY BUTTON



The button actuates a safety relay. When you activate the safety relay the machine will become operational and MAIN MENU will appear on the panel.

## START

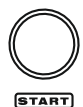

Press the button in S.A. mode to start the operating cycle (clamping the material, start of the saw blade motor and the coolant pump, arm feed towards the cut, lifting the arm into the specified position, switching off the saw blade motor and coolant pump, vice release).



In the MANUAL MODE, the saw blade will start upon pressing the button.

## SAW BLADE SPEED CONTROLLER



You can change the cutting speed using a saw blade speed controller (using a frequency converter) on the control panel.

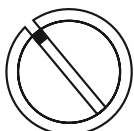

The display continuously shows the selected value within the range 15-90 m/min.

## STOP



Press the STOP button in S.A. MODE to interrupt the operating cycle. If the END STROKE SWITCH is in position 1, the saw blade will stop and the arm will travel upwards to the specified position. If the END STROKE SWITCH is in position 0, the saw blade will stop and the arm will remain in the current position.

Upon pressing the STOP button in the MANUAL MODE, the saw blade will stop.

## TOUCH SCREEN



Upon starting the machine with the MAIN SWITCH and loading the system, a yellow screen will appear. That means the safety relay is not activated.

Activate the safety relay by pressing the yellow backlit button. When you activate the safety relay, the machine will become operational and MAIN MENU will appear on the panel.

The yellow screen also appears during the operation of the saw, anytime the machine is stopped using the safety relay - by opening the arm cover or pressing TOTAL STOP. After the elimination of the cause the machine will become operational upon pressing the yellow backlit button.

## MAIN MENU

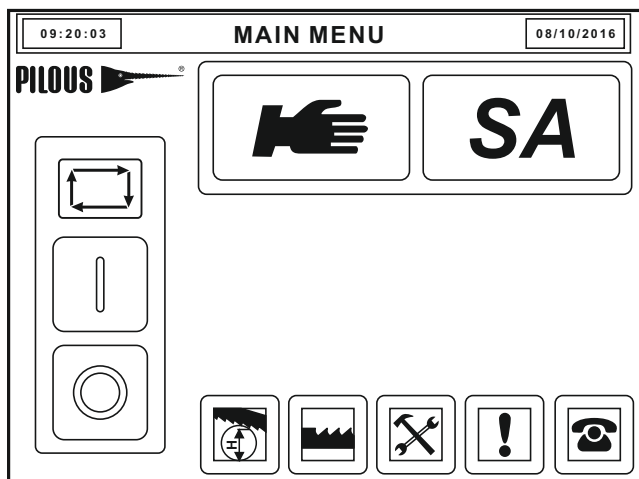

On the Main Menu screen you can access all machine functions regarding operation, settings or service. Control the screen by putting your finger on the area of a particular button.

After you press the TIME box, a screen with data about the operating status of the machine appears (applies to all screens in all modes).

Upright font - information box (not affected by touch)

Italic (symbol) font - buttons (touch to initiate the function, or jump to a different screen)

Note: Some information boxes or buttons are present on multiple screens. Each of them is described only once in the manual, because they possess the same function on all screens.

- |  |                       |  |                                   |
|--|-----------------------|--|-----------------------------------|
|  | <b>TIME</b>           |  | <b>SEMI-AUTOMATIC MODE</b>        |
|  | <b>DATE</b>           |  | <b>ARM LIFTING HIGH SETTING H</b> |
|  | <b>HYDRAULIC UNIT</b> |  | <b>SAW BLADES</b>                 |
|  | <b>START/STOP</b>     |  | <b>MACHINE SETTINGS</b>           |
|  | <b>MANUAL MODE</b>    |  | <b>FAILURE SCREEN</b>             |
|  |                       |  | <b>SERVICE CONTACT</b>            |

## SEMI-AUTOMATIC MODE

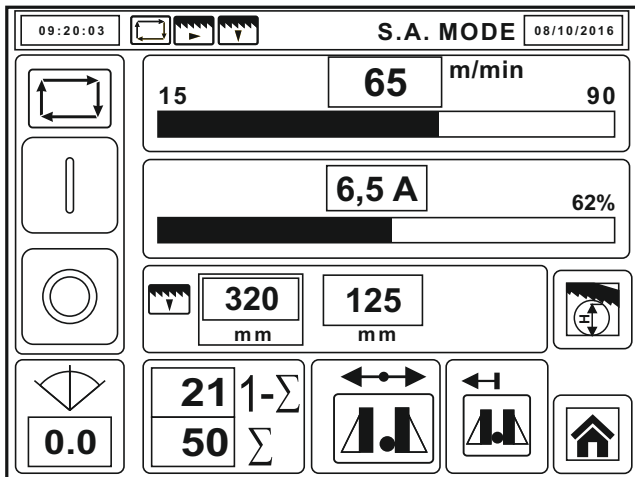

### Active features of the mode

- Hydraulics ON
- Saw blade upwards
- Saw blade downwards
- Saw blade ON

### HYDRAULIC UNIT START/STOP

Press the hydraulic unit START/STOP icon to start or stop the hydraulic unit.

### ANGLE - Accessories

Shows the screen angle of the saw blade. Press the icon in order to perform the calibration.



Saw blade speed 15-90 m/min

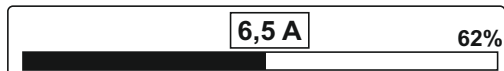

Ammeter - measures the saw band motor load

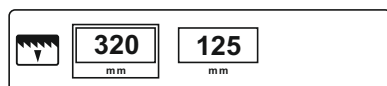

**320** Arm uplift height setting (editable)

**125** Current height of the arm

If you set the arm uplift to a higher value in the semi-automatic mode, the arm will ascend to the required height after pressing the **Enter** button.

If you set the arm uplift to a lower value in the semi-automatic mode, the arm will remain in the same position after pressing the **Enter** button and will ascend to the required height after performing the cut.



### ARM UPLIFT HEIGHT H SETTING

Press the icon in order to display a table for optimal setting of the height of the cut log.

### WORKPIECE COUNTER

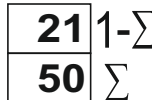

Number of completed workpieces

Set number of workpieces

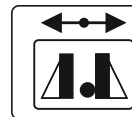

Vice open



Vice closed



If the vice is open, pressing the START button in the S.A. MODE executes the cycle and after its completion the vice remains open.

If the vice is closed, pressing the START button in the S.A. mode executes the cycle and after its completion the vice remains closed.



By pressing this button, you can only open the vice. This button is only in machines with full-uplift vice: ARG 380, 500 plus S.A.F.



Go to main menu, or a level higher.

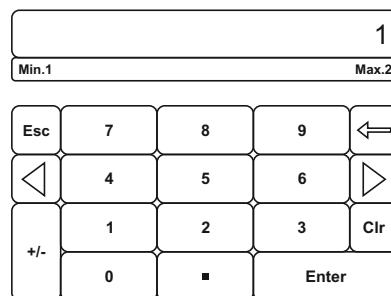

Esc Window cancelation

← Correct the set value

Enter Confirm the set value

## MANUAL MODE

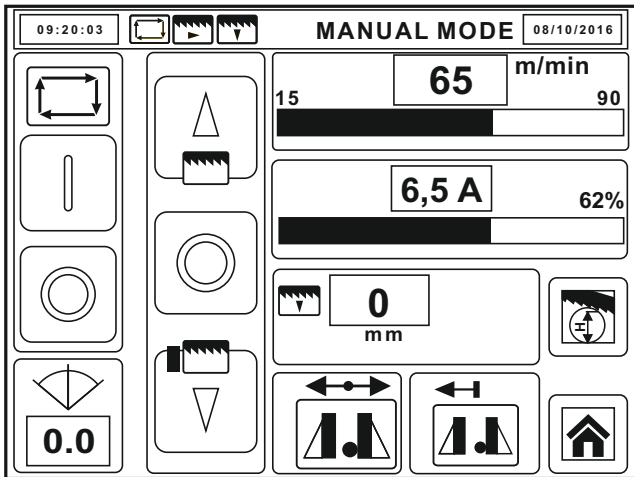

After switching on the hydraulic power unit, the START button lights up green. This indicates the machine is on. Blue boxes next to icons indicate reaching the particular extreme position (uplift/descent of the arm or switching the vice pressure switch). If you initiate any function that is logically preceded by a different function (that has not been activated yet), the button of the preceding function will start flashing to indicate error.

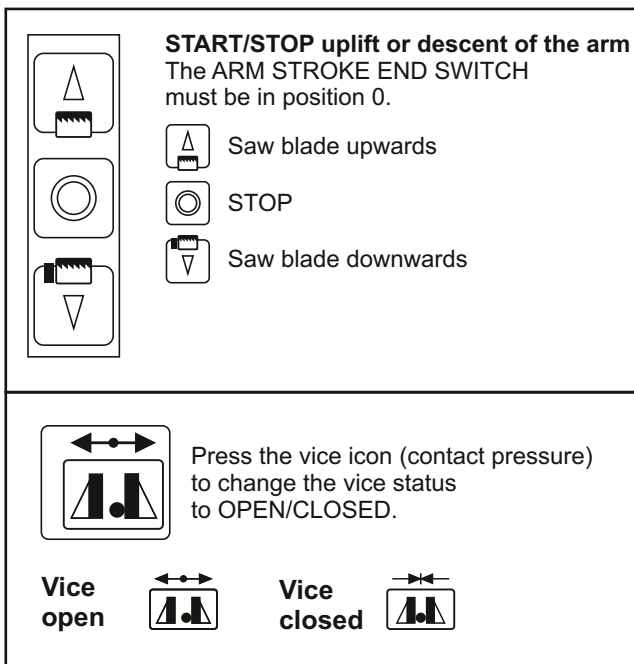

## MACHINE SETUP

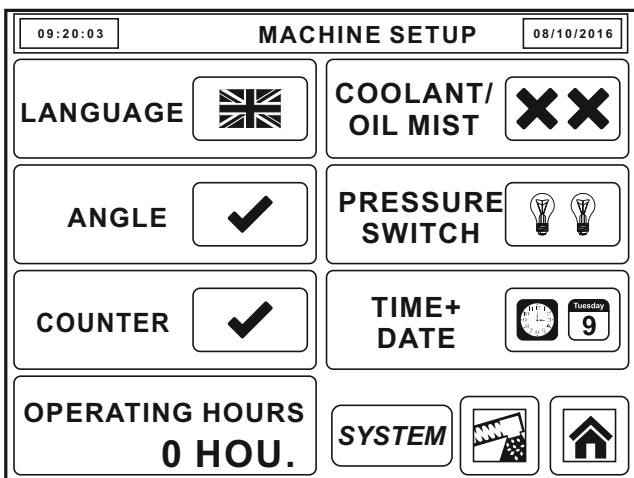

**LANGUAGE** - switch to the screen, selection of several languages.

**ANGLE** - enables displaying of the set angles on the display (accessories)

**COUNTER** - counts the number of cut workpieces in the current series

**OPERATING HOURS** - displays the time of operation of the hydraulic unit (regular changes of oil)

**BUNDLE CUTTING HVP** - HVP accessories actuation

**COOLANT/OIL MIST** - you can switch between cooling by coolant (red cross) or oil mist (accessories) (green tick)

**PRESSURE SWITCH** - switch to the screen with vice pressure switch settings

**TIME + DATE** - switch to the screen with system date and time settings

**SYSTEM** - switch to the system settings screen with converters, servo motors, PLC settings. The screen is locked - only the manufacturer or the distributor can edit the data.

**SCREW CONVEYOR OF CHIPS** - switch to a service screen for maintenance and cleaning of the machine



## ANGLE

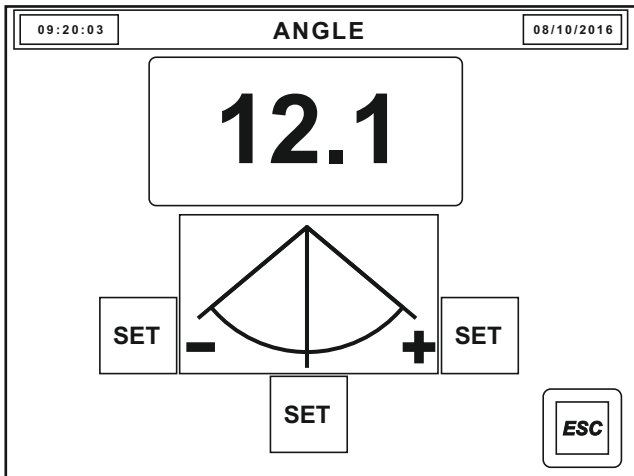

### Setting the cutting angle sensor - calibration

Using a framing square, align the orthogonality (90°) of the belt against the fixed vice jaws and press the middle SET button.

Turn the saw arm to the stop on the right (60°) and press the right SET button.

Turn the saw arm to the stop on the left and press the left SET button.

**Recommendation:** Using the space between the ends of the calibrated framing square and measuring the angle between the saw blade and the fixed jaw.

## ARM LIFTING HIGH SETTING H

The screenshot shows the 'ARM LIFTING HIGH SETTING H' menu with a table of diameter (D) and height (H) settings. A diagram of a saw arm is shown to the right of the table, with 'D' and 'H' labels indicating diameter and height respectively. An 'ESC' button is in the bottom right corner.

D	H	D	H	D	H	D	H
70	65	140	123	210	176	280	225
75	69	145	127	215	179	285	228
80	74	150	131	220	183	290	232
85	78	155	135	225	186	295	235
90	82	160	138	230	190	300	238
95	86	165	142	235	194	305	242
100	91	170	146	240	197	310	245
105	95	175	150	245	201	315	249
110	99	180	154	250	204	320	252
115	103	185	157	255	208	325	255
120	107	190	161	260	211	330	258
125	111	195	165	265	215		
130	115	200	168	270	218		
135	119	205	172	275	221		

### ARM LIFTING HIGH SETTING H

Set or currently displayed arm height (H) is measured at the fixed jaw. When cutting a log, it is possible to set a lower arm uplift according to the table and thus the arm does not need to ascend unnecessarily high.

**Example:** pipe/log in diameter 320 mm. According to the table, set the height of the arm uplift only to 252 mm. You save the cutting time significantly.

## TIME+DATE SETTING

The screenshot shows the 'TIME+DATE SETTING' menu. It has two main sections: 'TIME INPUT' and 'DATE INPUT'. The 'TIME INPUT' section has fields for H (0), M (0), and S (0). The 'DATE INPUT' section has a day selector (Tuesday) with a '9' in a box, and fields for DD (0), MM (0), and YYYY (0). A home button is in the bottom right corner.

Input the current time in dark grey boxes in the red-outlined box. After you input the time, press the **TIME INPUT** button to enter the set time into the system.

Input the current date in dark grey boxes in the red-outlined box. After the input, you have to press the **DATE INPUT** button to enter the specified date into the system.

## CHANGE BLADE

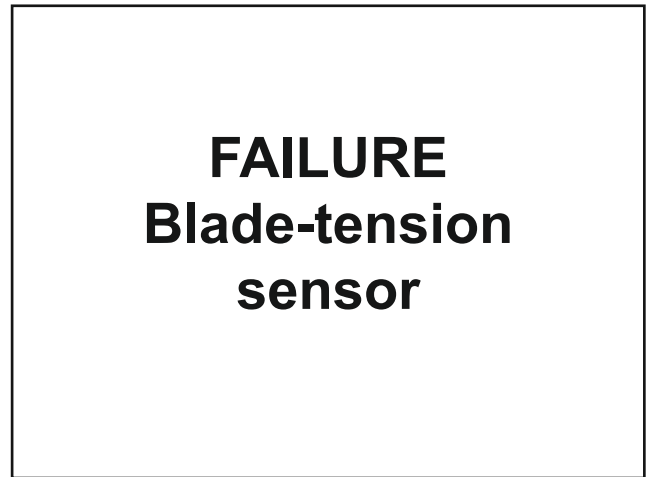
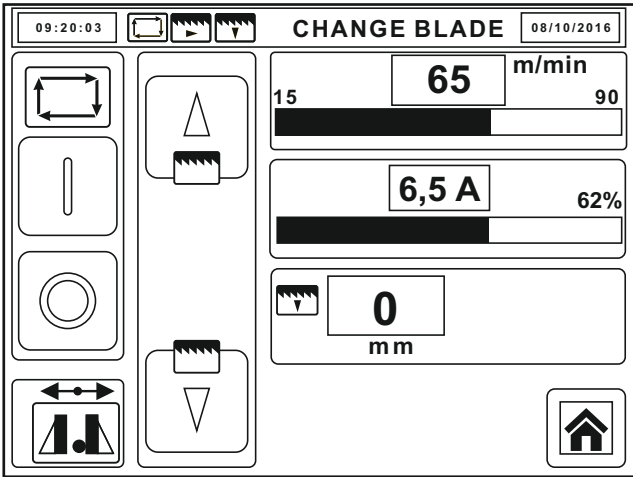



The screen CHANGE BLADE activates upon pressing the FAILURE Blade-tension sensor. The failure occurs in the event of saw blade breakage or loosening of the saw blade tensioning star nut.

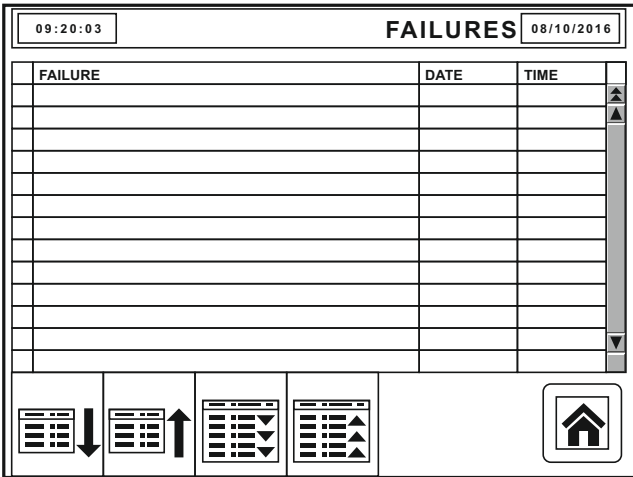

## FAILURES



The latest failure always appears on top and is not deleted. In the case of a new failure the previous failure will move to a line below. The system stores 200 failures. You can browse through the list using buttons.

The failures are displayed in colour:  
 red - current unresolved failure  
 green - resolved failure stored in the system

  Move to the next/previous line

  Jump to the last/first item in the list

## SERVICE

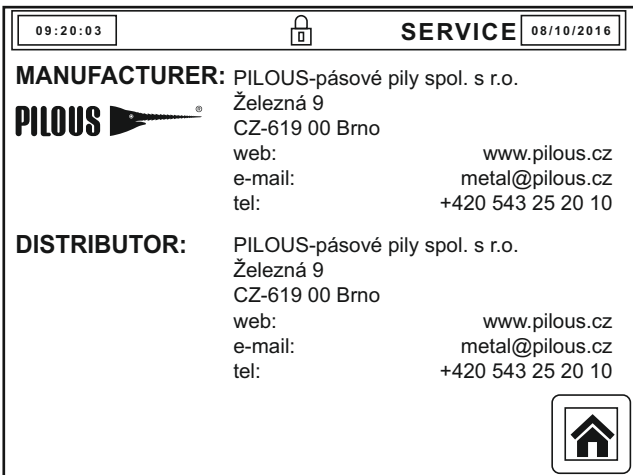

The display that informs the user about the machine manufacturer and distributor - contacts regarding the service in emergency.

The screen is locked - only the manufacturer or the distributor can edit the data.

## WORM CHIP TRANSPORTER

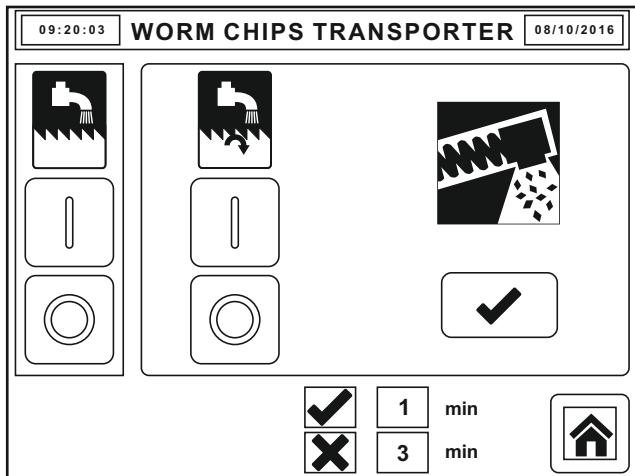

START/STOP coolant pump - for machine cleaning



START/STOP chips conveyor - for machine cleaning



If the chips conveyor is connected, tick as active



1

min

Here you can set the time interval of chips conveyor operation and the time interval of its inactivity while the saw blade is on.



3

min

## VICES PRESSURE-SENSORS SETTING

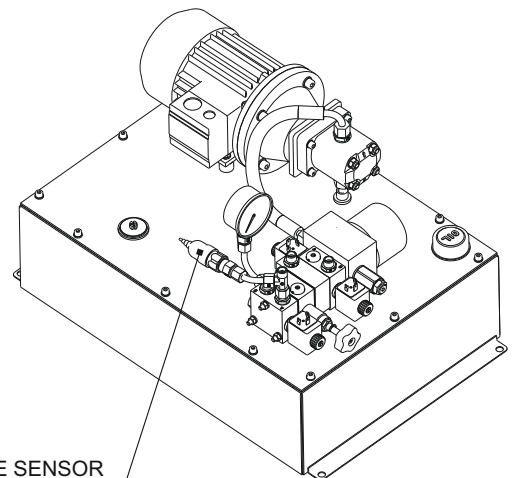
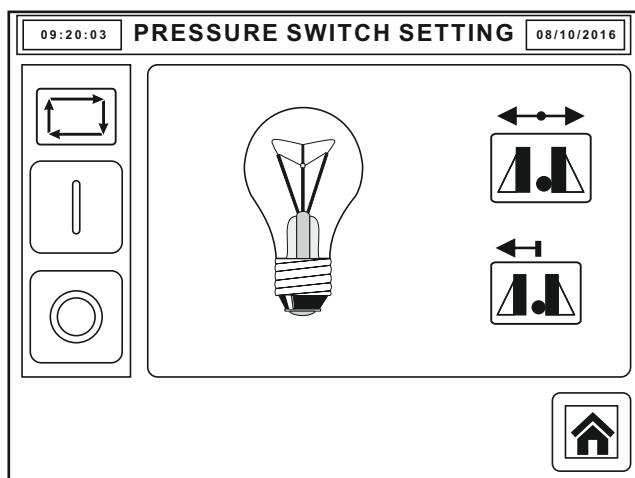

VICE PRESSURE SENSOR

The screen will appear in the event of manual input on the settings screen or if the PLC signal fades during the vice clamping. The machine immediately interrupts its operation and switches off the hydraulic unit, otherwise it may result in a hydraulic system leakage. Upon pressing the failures screen, a screen with settings appears, on which you can check the operation of pressure sensor.

You can check the function of pressure sensor after you start the hydraulic unit. When the vice is closed, the lamp must light up. If the vice is closed and the lamp is off, you have to adjust the pressure sensor (or identify another fault in the circuit). After releasing the vice, the lamp must go off. Press the vice icon to change the state of the vice - OPEN/CLOSED

### Pressure sensor settings

Insert the workpiece in the vice, switch on the hydraulic unit and clamp the vice. Light-bulb symbol on the PLC must light up. If it does not light up or if it is flashing, you have to adjust the pressure sensor.

Turn the adjusting screw on the pressure sensor (remove the black rubber cap, the screw is between two Faston connectors) to the right.

**Such operations may be carried out only by persons with electrician qualifications! Danger of short circuit of 24V contacts!**

Unclamp the vice. If the lamp is on while the vice is unclamped, turn the adjusting screw to the left.

Correct settings: Clamped vice - the lamp is ON

Unclamped vice - the lamp is OFF

## SYSTEM

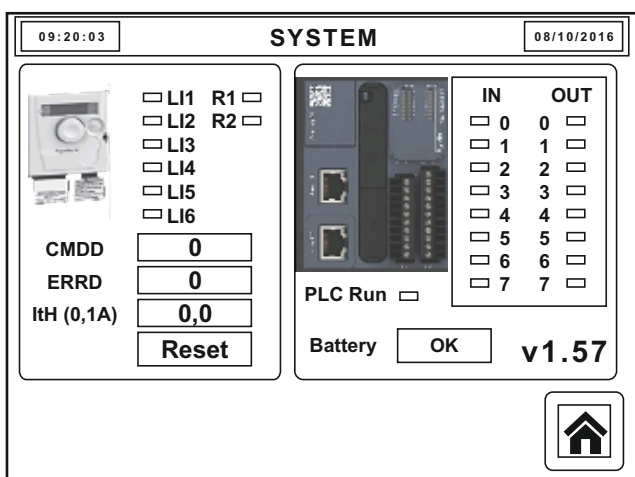

### Inputs (IN):

- 0 - Arm uplift sensor phase A IRC
- 1 - Arm uplift sensor phase B IRC
- 2 - Cycle/Blade Start SB3
- 3 - Cycle/Blade Stop SB4
- 4 - Lower arm position BP3
- 5 - Vice pressure sensor TS
- 6 - Screen angle sensor phase A LMIX
- 7 - Screen angle sensor phase B LMIX

### Outputs (OUT):

- 0 - Valve arm upwards
- 1 - Valve arm downwards
- 2 - Clamp the vice
- 3 - Unclamp the vice
- 4 - Hydraulic motor
- 5 - Mist
- 6 - Fault Indicator Lamp
- 7 - Cooling

## 4.2. Control Valve - Saw Blade Feed to the Cut

The control valve allows for a continuous setting of the velocity of saw blade feed towards the cut or stabilizing the saw arm in any position by mechanical closing. The optimum value of descent can be determined very easily by ear. The saw blade movement must be noiseless, free from vibrations. Such a state can be achieved by reducing or increasing the pressure force (by the velocity of saw arm descent). The prerequisite of setting the optimum pressure is selecting the correct saw blade velocity and the optimum size of the saw blade teeth.

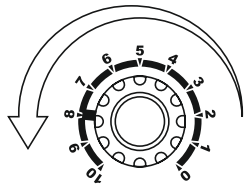

**ACCELERATION**  
SAW ARM DESCENT

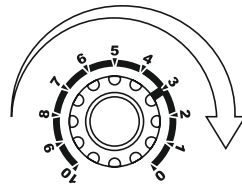

**DECELERATION**  
SAW ARM DESCENT

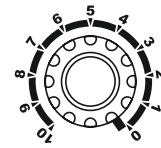

**STOP**  
SAW ARM DESCENT

## 4.3. Saw Blade Feed Pressure Control

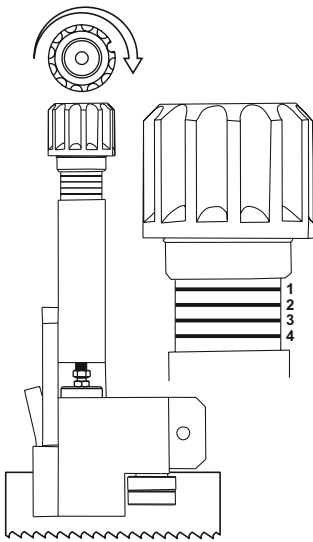

This system ensures the coordination of the cutting pressure and the saw blade feed to the cut in the real time, which is especially useful when cutting section materials. In the event of cutting of workpieces of larger sections, the cutting channel extends and the saw blade load increases. For instance, if cutting the H section, the arm initially descends fast, slows down in the middle (the cutting channel extends) and after cutting the transverse section, the resistance decreases and the arm increases its speed again. If the feed rate does not adjust automatically when cutting such range of sizes, the durability of the saw blade decreases significantly in the event of a too high feed, or it may lead to a significant increase of the cutting time in the event of a feed that is too low.

### Sensitivity settings:

The control sensitivity decreases when the control wheel is being screwed in.

1 - maximum sensitivity

4 - control off, the band saw arm always descends with the same velocity preset on the throttle valve arranged on the control board.

## 4.4. Vice

The hydraulic cylinder between the fixed clamping jaw and the jaw on the moving part of the vice facilitate workpiece clamping. Do not use the hydraulic cylinder to align long workpieces in the vice! Such operation has to be carried out only manually or by other means. You can set the clamping force depending on the type of material to be cut on the hydraulic unit using the VICE PRESSURE CONTROLLER (see section 4.9.1.).

### Workpiece clamping procedure:

Raise the arm above the presumed cross-section of the workpiece to be cut. Insert the material between the clamping jaws and align it parallel to the fixed clamping jaw and set the desired cut length. Slide the clamping jaw of the moveable vice to a distance approx. 10 mm from the cut material (the clamping uplift of the hydraulic cylinder is 15 mm in ARG 330, 20 mm in ARG 400, and adjustable in ARG 380 and 500). Clamp the workpiece in accordance with the current mode of the band saw, S.A. or MANUAL, and clamp the workpiece. **Check whether the workpiece is properly clamped, otherwise you risk its ejection during cutting.**

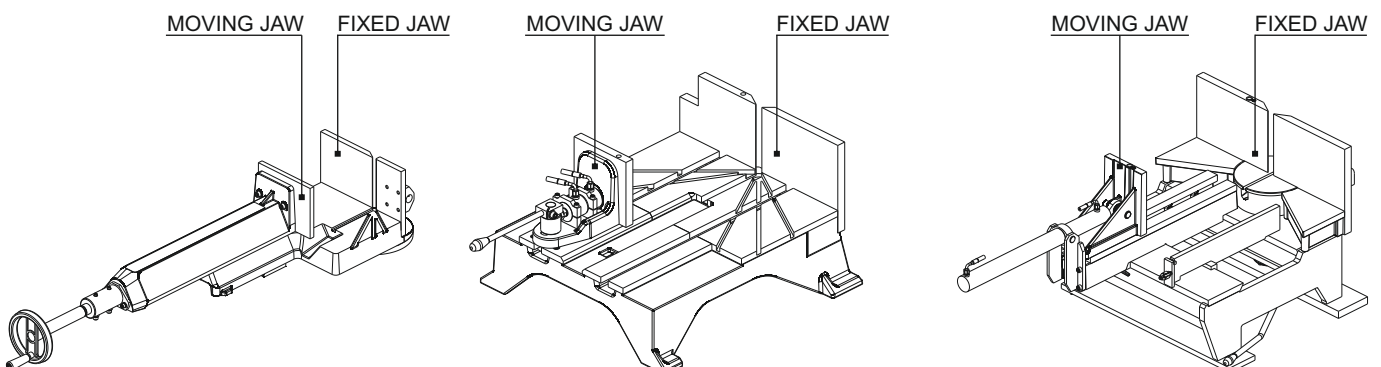

#### 4.4.1. Adjustment Procedure - Lateral Play of the Vice for ARG 330 S.A.F. and ARG 330 plus S.A.F.

Adjust the lateral play of the vice in the following way:

- ① Open the movable vice jaw to maximum extent.
- ② Loosen the M8 LOCKING NUTS and loosen the M8 VICE PLAY SETTING SCREWS.
- ③ Carefully tighten the first VICE PLAY SETTING SCREW (right at the movable clamping jaw) up to a point, where you feel that the screw (through a supporting ball) rested on the bar that pushes to the groove.
- ④ In this position, tighten the screw with an M8 LOCKING NUT against loosening.
- ⑤ Use the handwheel to move the VICE MOVING BODY, so that the next VICE PLAY SETTING SCREW is in the same position as the previous screw.
- ⑥ Repeat points ③, ④, ⑤ until the vice is completely closed and therefore adjusted.

You can watch the video with instructions on [www.pilous.cz](http://www.pilous.cz).

##### ARG 330 S.A.F.

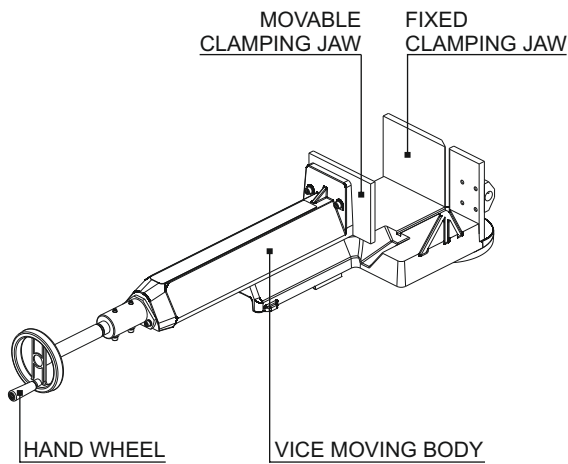

##### ARG 330 plus S.A.F.

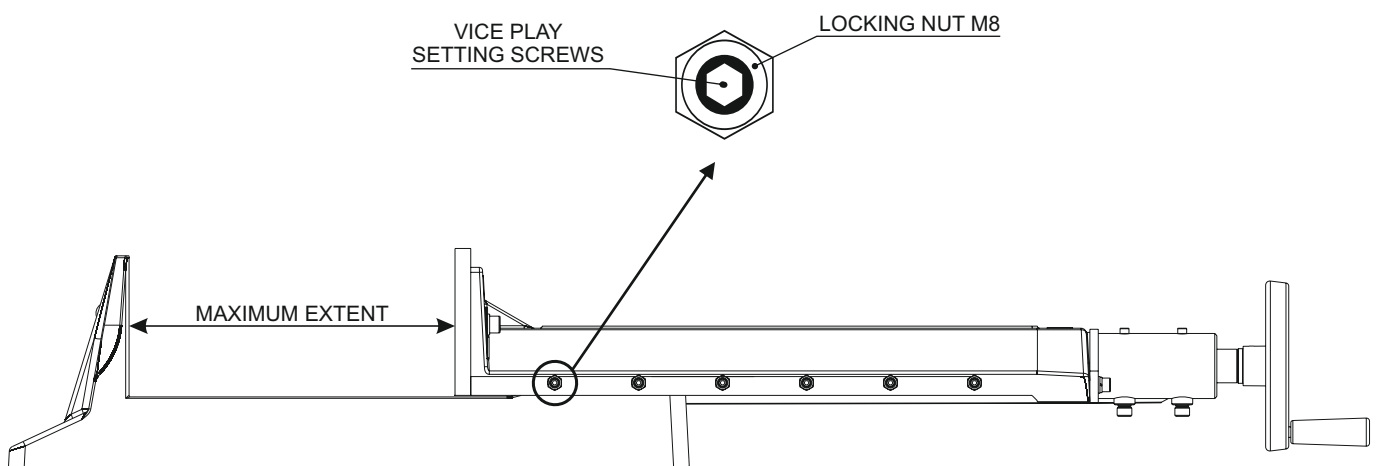
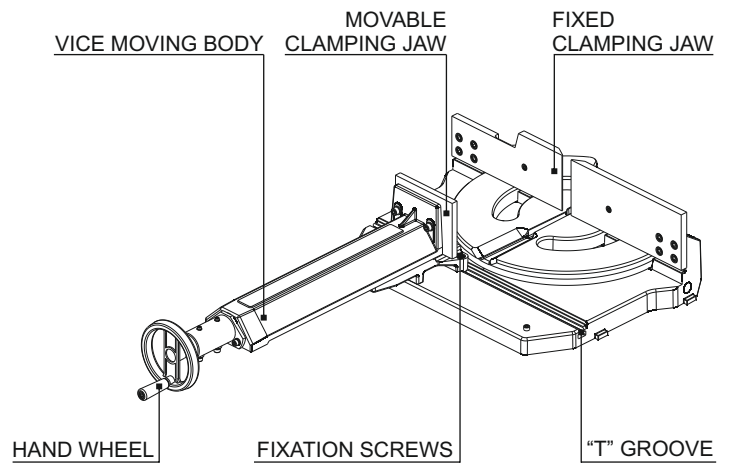

### 4.4.2. Cutting Angle Settings

ARG band saws allow for both perpendicular cuts and cuts up to 60°. The band saw ARG 330 S.A.F. allows for single-sided continuous cutting angle settings within 60° to the right side. Band saws ARG 330 PLUS S.A.F. and ARG 400 PLUS S.A.F. allow for double-sided continuous cutting angle settings within 60° to the right and 45° to the left. Band saws ARG 380 PLUS S.A.F. and ARG 500 PLUS S.A.F. allow for double-sided continuous cutting angle settings within 60° to the right and 60° to the left. The stop bolts facilitate a stable limit angle setting. Before you swing the arm, unlock the arm with the locking lever and after setting the desired angle, lock the arm again. The desired arm swing angle will subtract from the angle scale. By the band saws of the PLUS line, before you swing the arm, mind the correct vice positioning in relation to the desired swing angle in order to prevent a collision of the arm/blade with the vice. If there is a danger of collision, loosen the adjusting screws of the vice (by ARG 380 and ARG 500 loosen the dovetail handles under the vice) and move the vice in the T groove to the other side, while the arm is raised, and lock the vice again. When swinging the arm of the ARG 330 S.A.F. and the ARG 400 plus S.A.F., raise the arm to about 40 mm above the loading surface of the vice in order to prevent the collision of the saw blade with the vice loading surface. If using the band saw only for perpendicular cuts for a longer time, we recommend that you carry out a precautionary step and swing the band saw into the angle and back at least once a week, because the coolant acts aggressively, which can result in jamming of the arm in one position.

**WARNING! When using the vertical vice while cutting the workpieces in HVP bundles, you can cut only at 90°.**

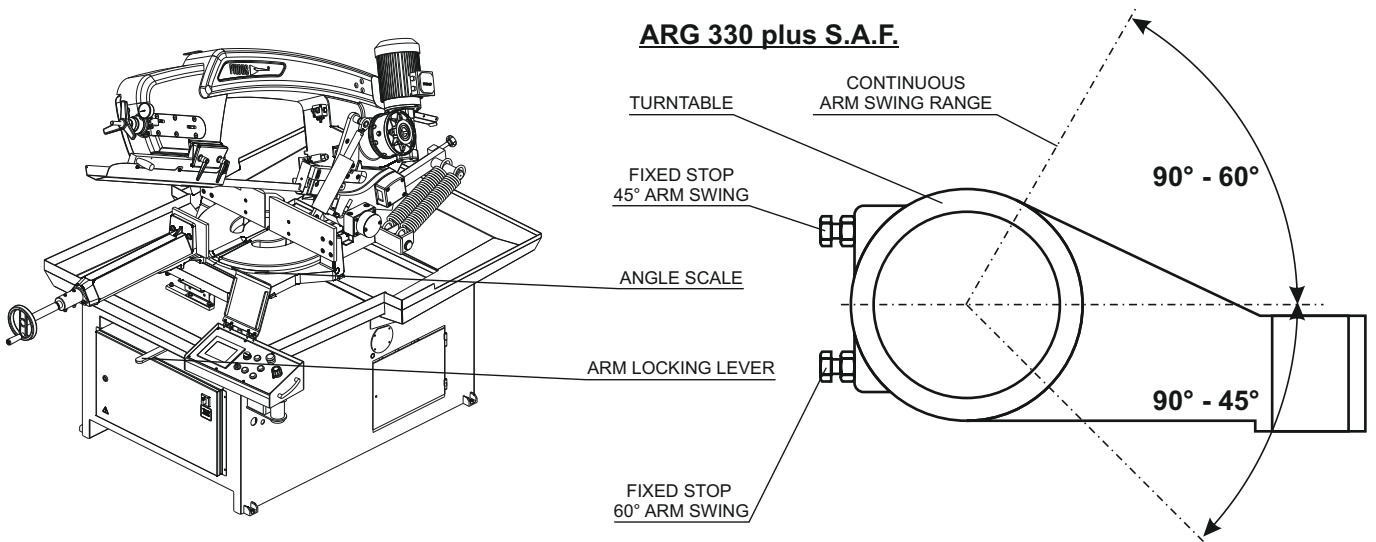
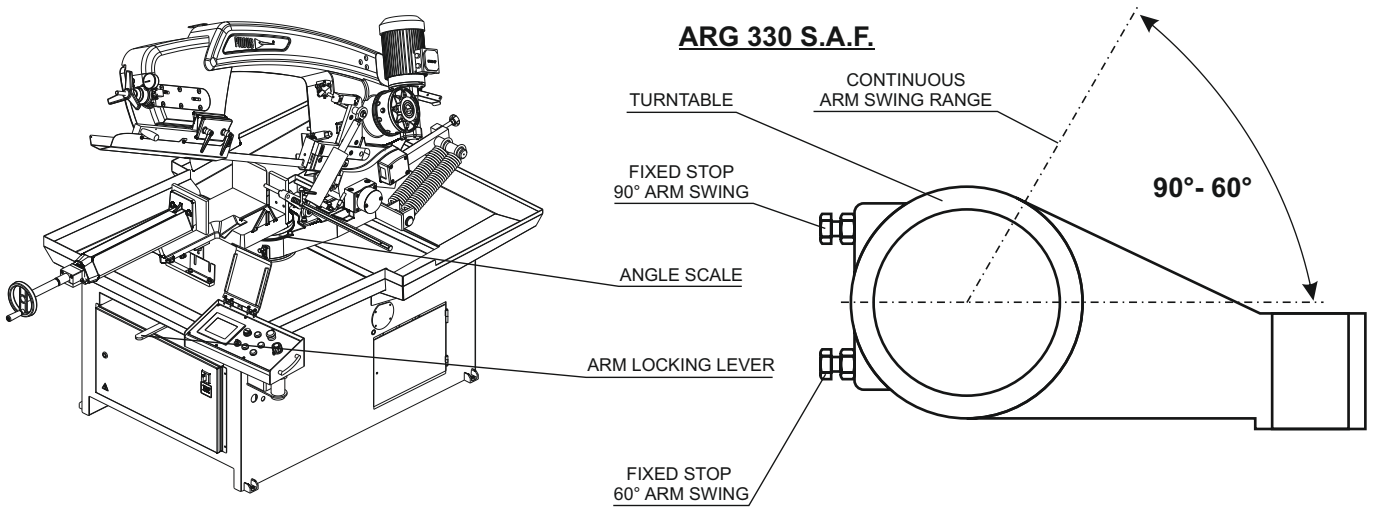

# ARG 400 PLUS S.A.F

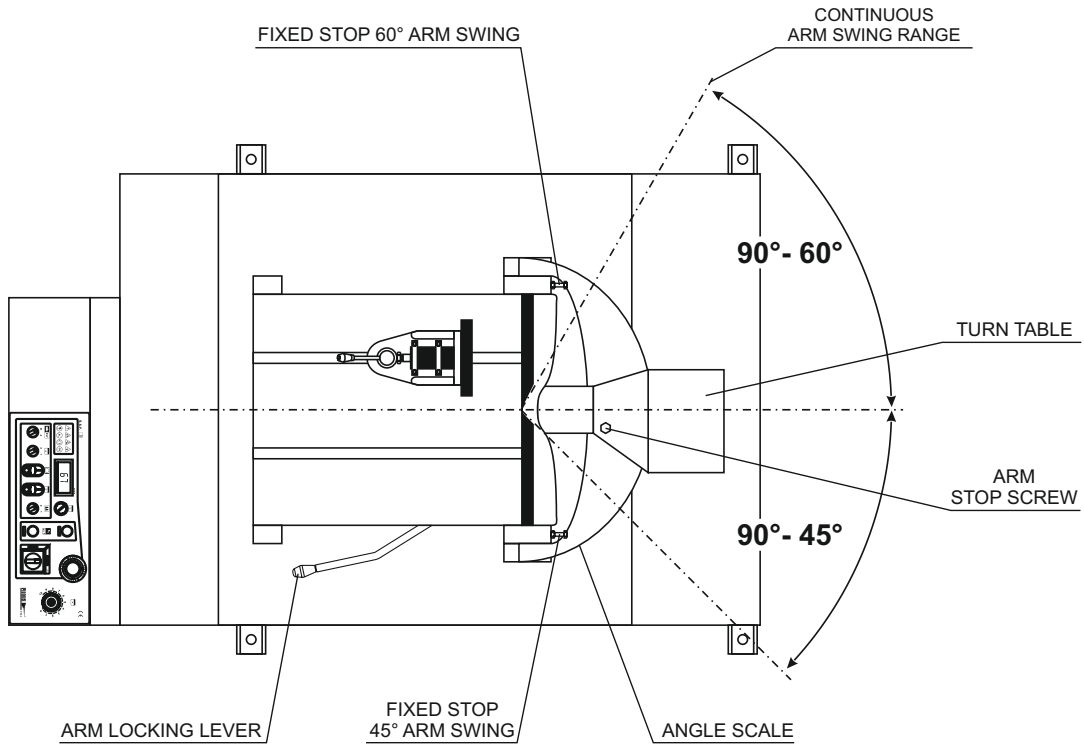

# ARG 380 PLUS S.A.F., ARG 500 PLUS S.A.F.

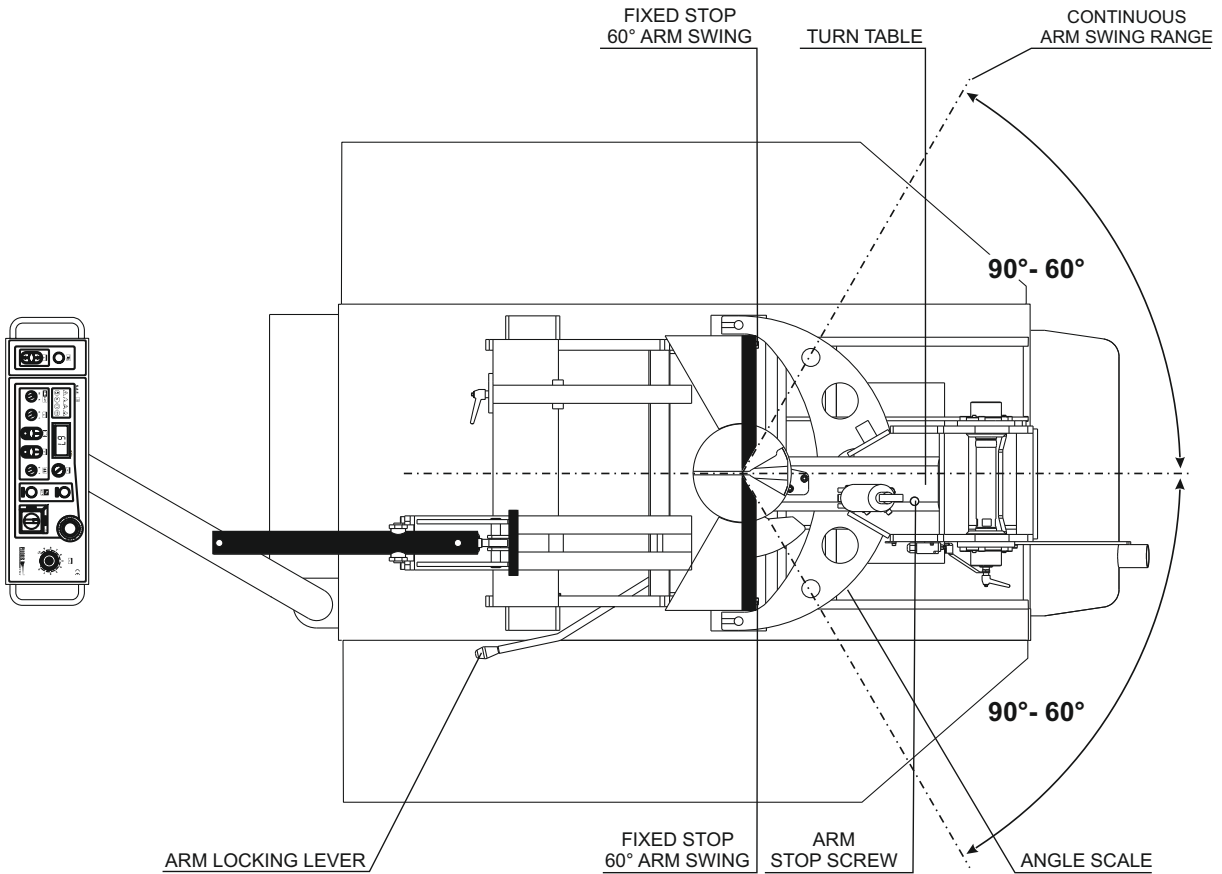



## 4.5. Arm - saw blade guidance

The arm of the ARG 330 S.A.F., ARG 330 plus S.A.F. and ARG 400 plus .S.AF. is made of a robust casting from grey cast iron. The casting is hollow, which ensures extraordinary stiffness when tensioning the saw blade. The arm of the ARG 380 plus S.A.F., ARG 500 plus S.A.F. is a massive welded steel structure. The saw blade is guided by two guide heads both behind and in front of the cut. The heads are fitted with eccentrically placed bearings and hardened steel blade guides that allow easier rewinding of the saw blade as opposed to wheel guidance. The fixed guide block is placed on a fixed guide bar and the movable guide block is placed on the movable bar. The moving guide block moves towards the cut material by 30-50 mm manually.



**Danger of injury - no cover in the machining area!**

## 4.6. Removal of Protective Covers



**Caution: You can remove protective covers only if the power switch is turned off and secured against restart or if the machine is disconnected from the mains.**

**Caution: Danger of injury by the sharp teeth of the saw blade. Use protective gloves. Do not reach between the running wheels and the saw blade.**

### 4.6.1. Removal of protective covers of the saw blade in ARG 330 S.A.F., ARG 330 PLUS S.A.F., ARG 400 PLUS S.A.F.

Connect the machine to the mains and press the POWER SWITCH. The TOTAL STOP button is unlocked. Start the MANUAL MODE, switch on the HYDRAULIC UNIT - START. Switch the ARM END STROKE SWITCH into position 0 in order to control fully the arm movement via the touch screen. Raise the arm into the upper position by pressing the SAW BLADE UPWARDS button and stop the uplift by pressing the STOP button on the display. Shut off the CONTROL VALVE completely (see section 4.2.). Start the saw arm descent and by gradually releasing the CONTROL VALVE move the arm to about 30mm above the fixed jaw of the vice and close the CONTROL VALVE. Switch off the POWER SWITCH and secure it against restart.

#### ARG 330 S.A.F., ARG 330 plus S.A.F.

Unscrew and slide out the cover of the front rod (A) and place it aside. Unscrew the blade cover (B) and place it aside. Unlock the angled shoulder bolts and tilt the rear cover of the arm (C) upwards and secure by bolts. Use a reverse procedure to mount back the protective covers.

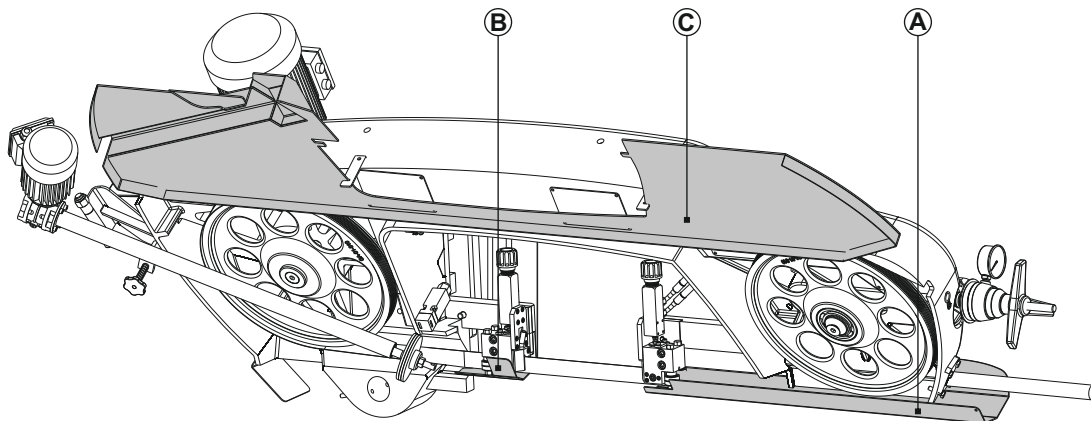

#### ARG 400 plus S.A.F.

Unscrew the blade cover (D) and place it aside. Unscrew and slide out the cover of the front rod (A), place it aside and unlock the angled latch (B). Tilt (1) the back cover of the arm (C), lift in the front part (2) and by moving it backwards (3) slide out the back cover. If you want to put the cover back on the machine, use a reversed procedure.

Turn on the POWER SWITCH and the hydraulic unit.

S.A. MODE - the arm is situated in between the limit switches, therefore it is necessary to switch the ARM END STROKE SWITCH into position 1 and the arm will travel to the upper position. Now you can start cutting and the descent; press the green button START and the semi-automatic cycle will start.

MANUAL MODE - press the SAW BLADE UPWARDS button and the arm will also travel into the upper position; or press the SAW BLADE DOWNWARDS button and the arm will travel to the lower position (ARM END STROKE SWITCH must be set in position 0).

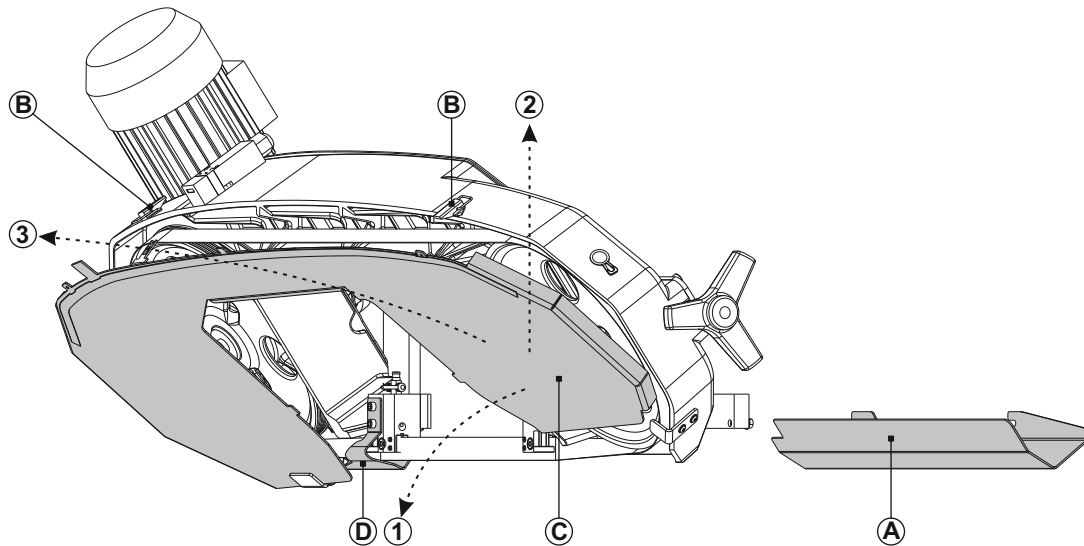

#### 4.6.2. Removal of protective covers of the saw blade in ARG 380, 500 plus S.A.F.

Connect the machine to the mains and press the POWER SWITCH. The TOTAL STOP button is unlocked. Start the MANUAL MODE, switch on the HYDRAULIC UNIT - START. Switch the ARM END STROKE SWITCH into position 0 in order to control fully the arm movement via the touch screen. Raise the arm into the upper position by pressing the SAW BLADE UPWARDS button and stop the uplift by pressing the STOP button on the display. Shut off the CONTROL VALVE completely (see section 4.2.). Start the saw arm descent and by gradually releasing the CONTROL VALVE move the arm to about 50mm above the fixed jaw of the vice and close the CONTROL VALVE. Close the vice so that the cover of the front moving block slides from the front part of the arm - tensioning wheel. Switch off the POWER SWITCH and secure it against restart. Open the covers A, then flip up covers B, C and unscrew the cover D. Mount back the covers using reverse procedure. Turn on the POWER SWITCH and the hydraulic unit.

S.A. MODE - the arm is situated in between the limit switches, therefore it is necessary to switch the ARM END STROKE SWITCH into position 1 and the arm will travel to the upper position. Now you can start cutting and the descent; press the green button START and the semi-automatic cycle will start.

MANUAL MODE - press the SAW BLADE UPWARDS button and the arm will also travel into the upper position; or press the SAW BLADE DOWNWARDS button and the arm will travel to the lower position (ARM END STROKE SWITCH must be set in position 0).

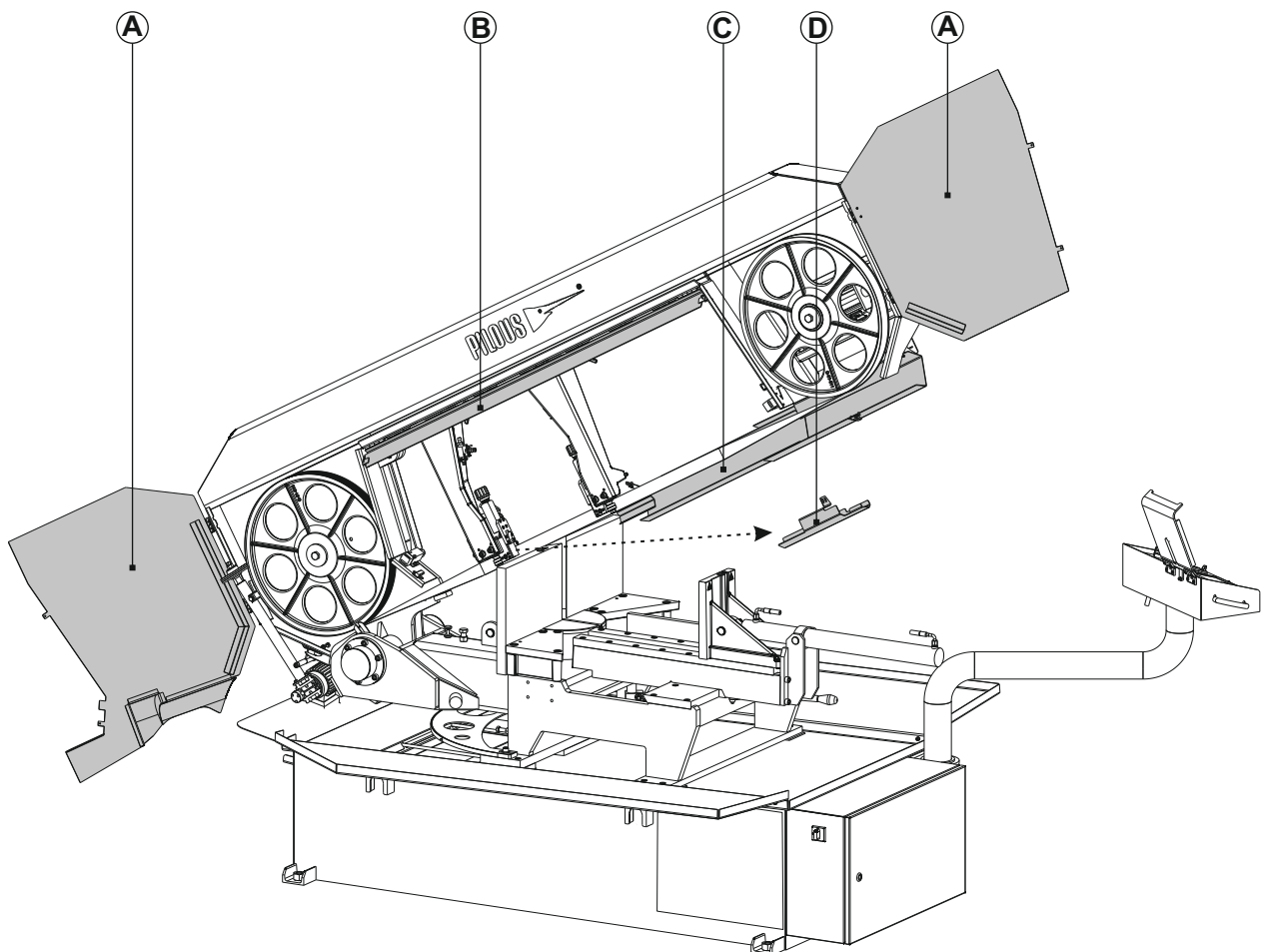

## 4.7. Replacement, tensioning and adjustment of the saw blade

A timely replacement of the saw blade is needed to achieve good cutting performance, surface finish quality and compliance with workpiece dimensions. Blunt saw blades cause high consumption of electrical power, scarf cuts and rough cutting surfaces. One of the decisive factors affecting the quality of the cut and the life of the cutting tool is a correct and sufficient saw blade tension.

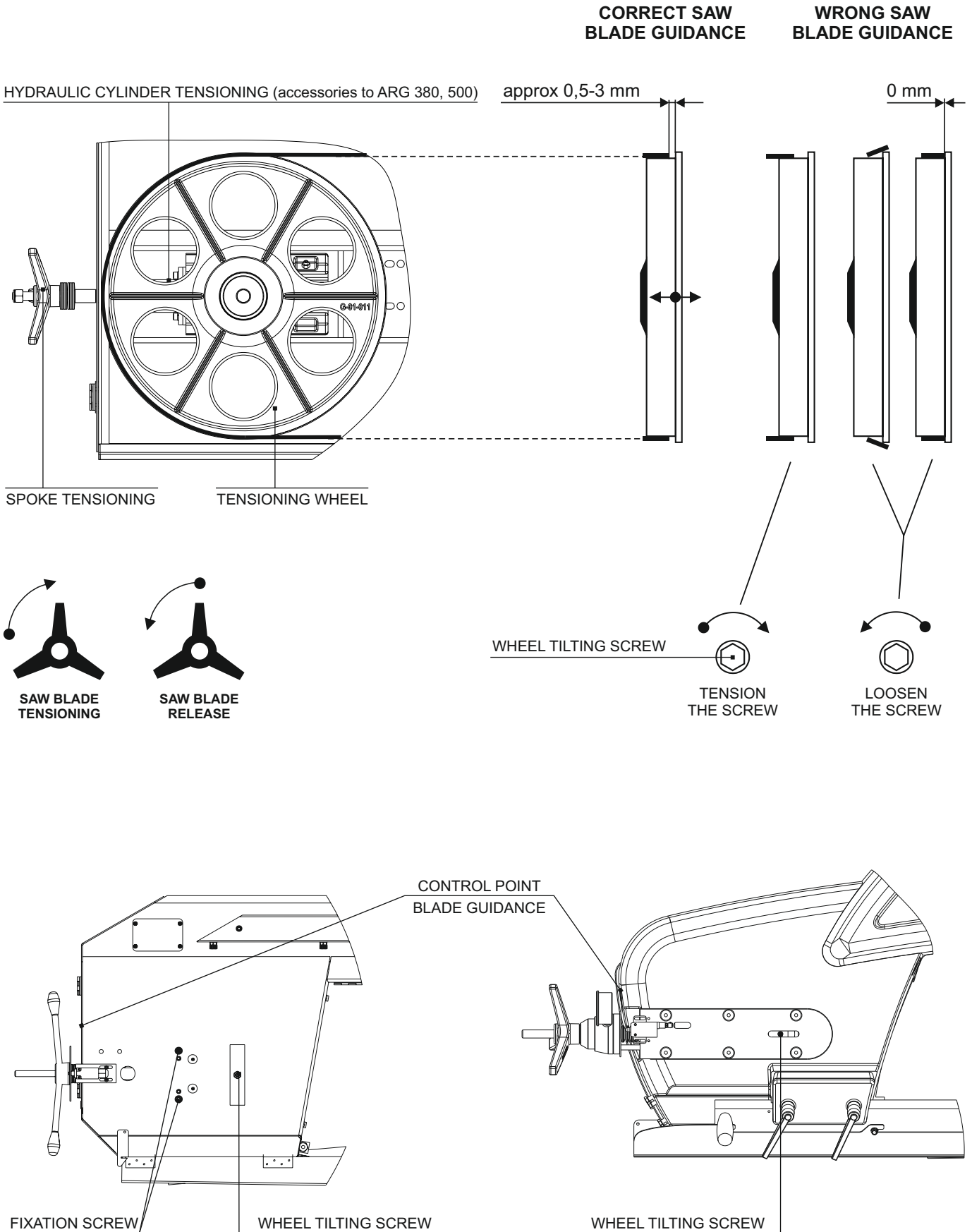

Connect the machine to the mains and press the MAIN SWITCH. The TOTAL STOP button is unlocked. Start the MANUAL MODE, switch on the HYDRAULIC UNIT - START. Switch the ARM END STROKE SWITCH into position 0 in order to control fully the arm movement via the touch screen. Raise the arm into the upper position by pressing the SAW BLADE UPWARDS button and stop the uplift by pressing the STOP button on the display. Shut off the control valve (see section 4.2.). Start the saw arm descent and by gradually releasing the CONTROL VALVE move the arm to about 30mm (in ARG 330) above the fixed jaw of the vice (50 mm in other types) and close the CONTROL VALVE. Switch off the MAIN SWITCH and secure it against restart.



**Caution! You can remove protective covers only if the power switch is turned off and secured against restart or if the machine is disconnected from the mains.**  
**Caution: Danger of injury by the sharp teeth of the saw blade. Use protective gloves. Do not reach between the wheels and the saw blade.**

Open/remove the protective covers of the saw blade (see section 4.6.). Use the tensioning star nut to release the wheel and the blade. Take the saw blade off the moving wheels and push it off the guide heads. Insert the new saw blade in the guide heads. Place it on the blade wheels (you can control the position of the tensioning wheel by the tensioning star nut). Tighten the saw blade. **Tension the star nut, so that the disc springs are fully compressed (no light coming through)! In this way, you can achieve correct tensioning of the saw blade.** Close/put back the protective covers of the saw blade and turn on the MAIN SWITCH. Turn on the hydraulic unit, switch to the MANUAL MODE and set the minimum saw blade speed by a SAW BLADE SPEED CONTROLLER. Press the START button of the saw blade to start the saw blade so that it turns approximately one full length. Switch off the MAIN SWITCH and secure it against restart. Open/remove the protective covers of the saw blade to make sure that the saw blade is correctly fitted on the guide heads and correctly installed on the blade wheels (see figure). The machine is also fitted with a control hole that allows you to check the condition of the saw blade on the wheels. The hole is covered by a cap.

If the saw blade is not properly set on the wheels, loosen the saw blade a little bit and use the wheel tilting screw to adjust the wheel tilt. Tension the saw blade again and close/put back the protective covers of the saw blade. **Tension the star nut, so that the disc springs are fully compressed (no light coming through)!** Turn on the MAIN SWITCH and the hydraulic unit. Carry out a saw blade trial run. Switch off the MAIN SWITCH and secure it against restart, open/remove the protective covers of the saw blade and once again check the placement of the saw blade on the wheels. Repeat the procedure, if required. Close/put back the protective covers of the saw blade and turn on the MAIN SWITCH and the hydraulic unit. Carry out the cutting.

## 4.8. Guide Heads Adjustment

The correct setting of the bearings and the hardened steel blade guides in the guide heads substantially influences the saw blade life and the quality of the cut. The eccentrically arranged guide head bearings must be set in such a manner that the saw blade surface is parallel to the surface of hardened steel blade guides. One of the hardened steel blade guides is fixed firmly, the other one is adjustable.

### Guide Head Setting Procedure

Raise the saw blade approx. 30 mm (in ARG 300) above the fixed vice jaw (50 mm in other types). Switch off the MAIN SWITCH and secure it against restart. Disconnect the coolant supply hoses from the guide heads and the control head (the hydraulic hoses must never be disconnected!). Loosen the tensioning star nut in order to loosen the saw blade. Open/remove the protective covers of the saw blade. Take the saw blade off the moving wheels and push it off the guide heads. Unscrew the guide heads gradually from the fixed and moving guide bars and clean them thoroughly. Fasten the guide heads to the fixture approx. 350 mm from each other and turn them through 180° (with bearings and hardened steel blade guides upwards). Make sure that the guide heads are perpendicular to the guide bars and that the height of the guide heads is identical. Check the tightening of the fixed hardened steel blade guides. Insert approximately 50 cm of an old saw blade in the guide heads between the hardened steel blade guides and the bearings. When the saw blade has been adjusted, set the eccentrically mounted bearings in such a manner that the bearings do not "cut" the saw blade, but at the same time you have to prevent too much space for the saw blade between the bearings. When the saw blade moves, the bearings are carried along by the saw blade. Adjust the control bearing with the control cylinder liner so that the bearing axis is perpendicular to the saw blade. Make sure that all bolt connections are tight. Unscrew the guide heads from the fixture. Fit the saw blade on the wheels, check its correct alignment on the wheels and tension the saw blade. Install both guide heads on the saw blade in the space between the bars and adjust them in the correct position on the bars. In this way, the correct guide head height towards the guide bars is achieved. Adjust the heads in such a way that the saw blade is in perpendicular position to the machine table and tighten them. Connect the coolant hoses and the saw blade pressure control heads. Close/put back the protective covers of the saw blade and turn on the MAIN SWITCH. Switch on the hydraulic unit and carry out a short trial run of the saw blade. Switch off the MAIN SWITCH and secure it against restart. Open/remove the protective covers of the saw blade and check the placement of the saw blade on the wheels. Make a correction, if necessary - see section 4.7.. Close/put back the protective covers of the saw blade and turn on the MAIN SWITCH and the hydraulic unit. Carry out the cutting.

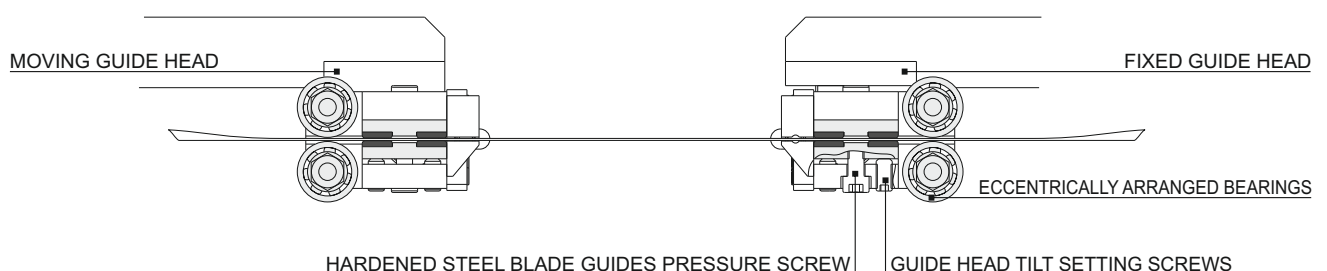

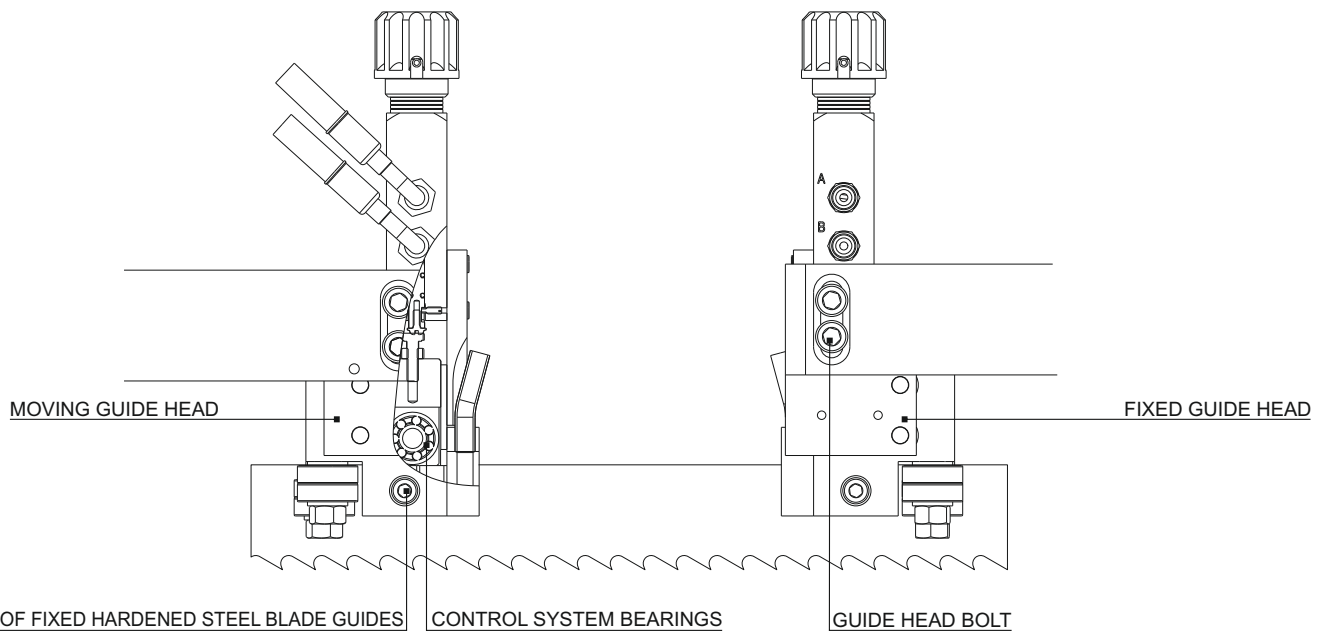
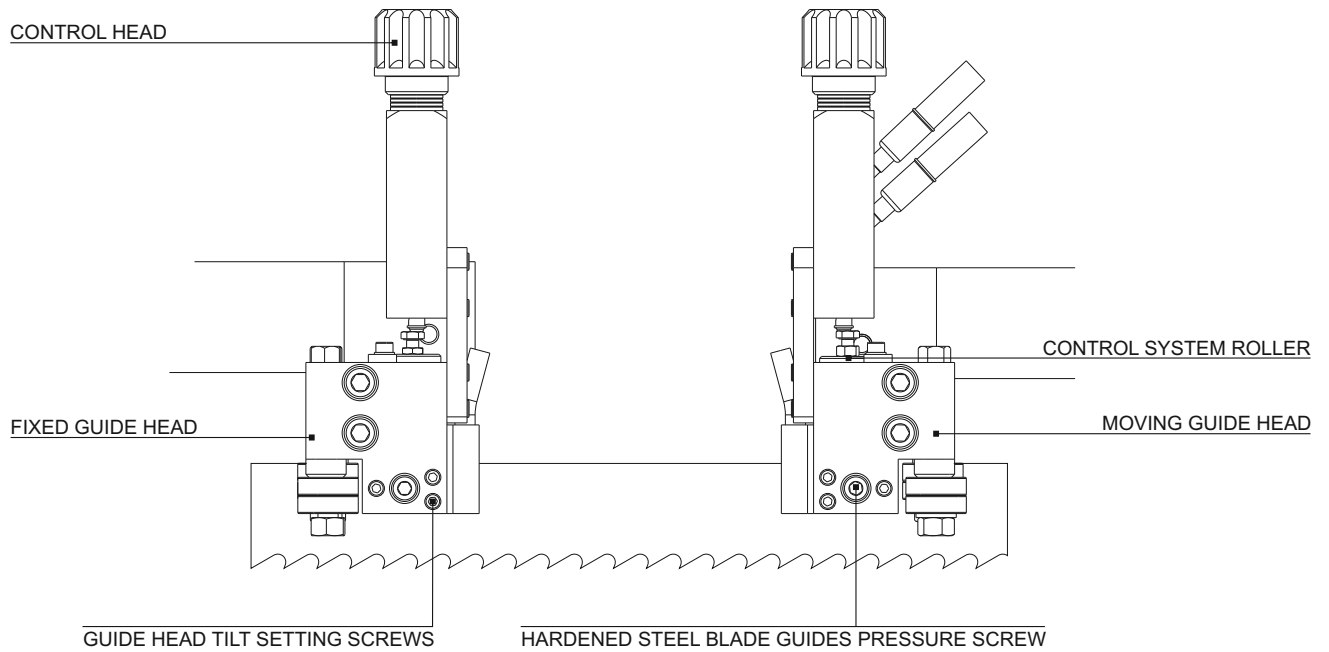

### Guideheads without saw blade feed pressure control

You can achieve the correct height of guide head in relation to the saw blade using the screws to set the upper bearing by 0.3-1 mm closer to the saw blade than the hardened steel blade guides. In this case, there will be no clearance between the upper bearing and the blade edge and the bearing will be carried along by the blade.

Set the guide heads perpendicular to the bars and tighten them. If you fail to achieve perpendicularity, the saw blade will either keep sliding off or running into the wheels. Install the protective covers of the saw blade and close the back cover of the arm. Turn on the MAIN SWITCH or connect the machine to the mains. Carry out a saw blade trial run. Switch off the MAIN SWITCH or disconnect the machine from the mains and secure it against restart. Remove the protective covers of the saw blade and open/remove the back cover of the arm. Check the placement of the saw blade on the wheels and in guide heads. Make a correction, if necessary - see section 4.7.. Install the protective covers of the blade, close the back cover of the arm and turn on the MAIN SWITCH or connect the machine to the mains. Carry out the cutting. You can watch the video with instructions on [www.pilous.cz](http://www.pilous.cz).

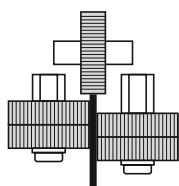
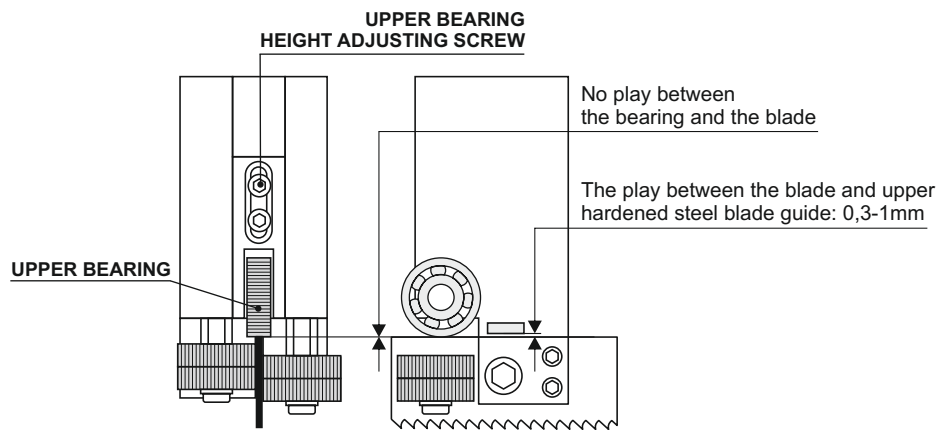
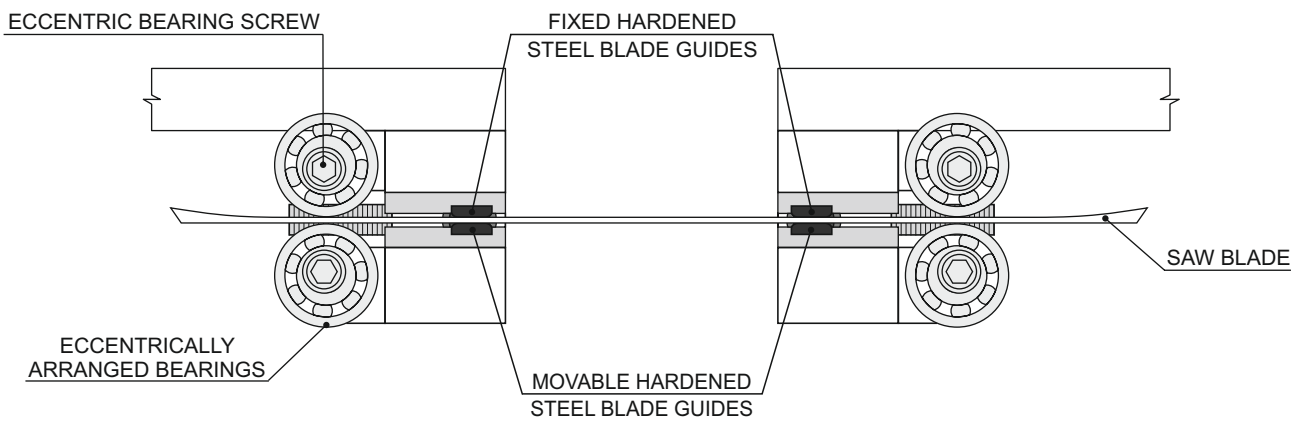
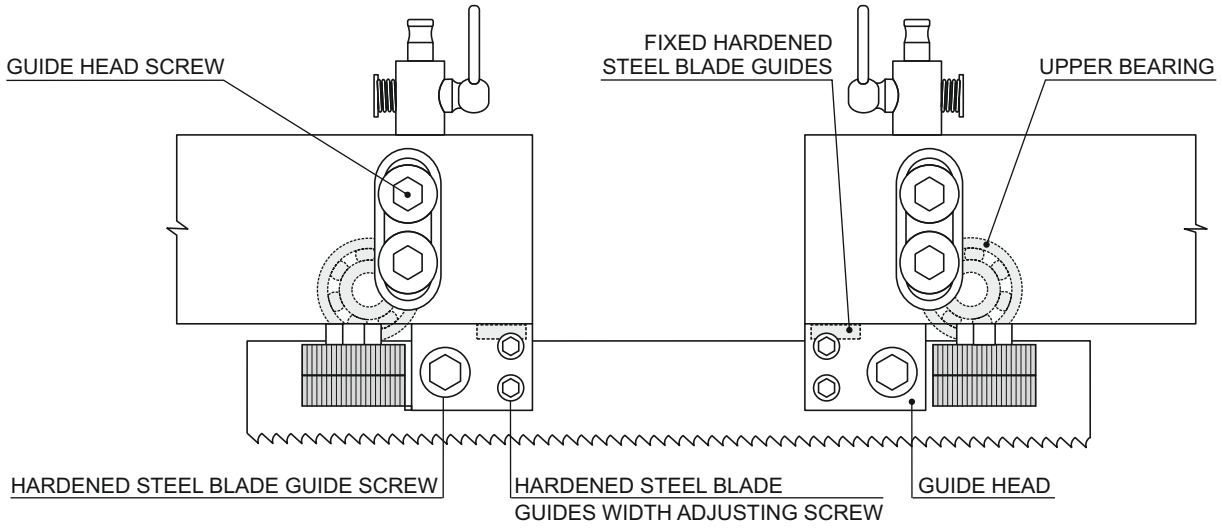

**Correct saw blade guidance**  
to center between guide bearings

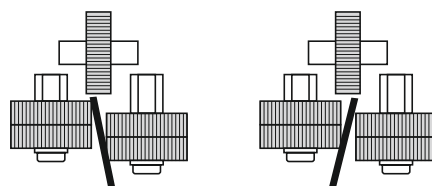

**Incorrect saw blade guidance**



## 4.9. Hydraulic Unit

The hydraulic unit is installed in the machine base. It lifts the band saw arm, feeds the saw blade to the cut, feeds the arm to the cut and clamps and unclamps the vice. When the MASTER SWITCH is on, the HYDRAULIC UNIT - START button serves for activating the electrical system of the machine and at the same time for starting the hydraulic unit.

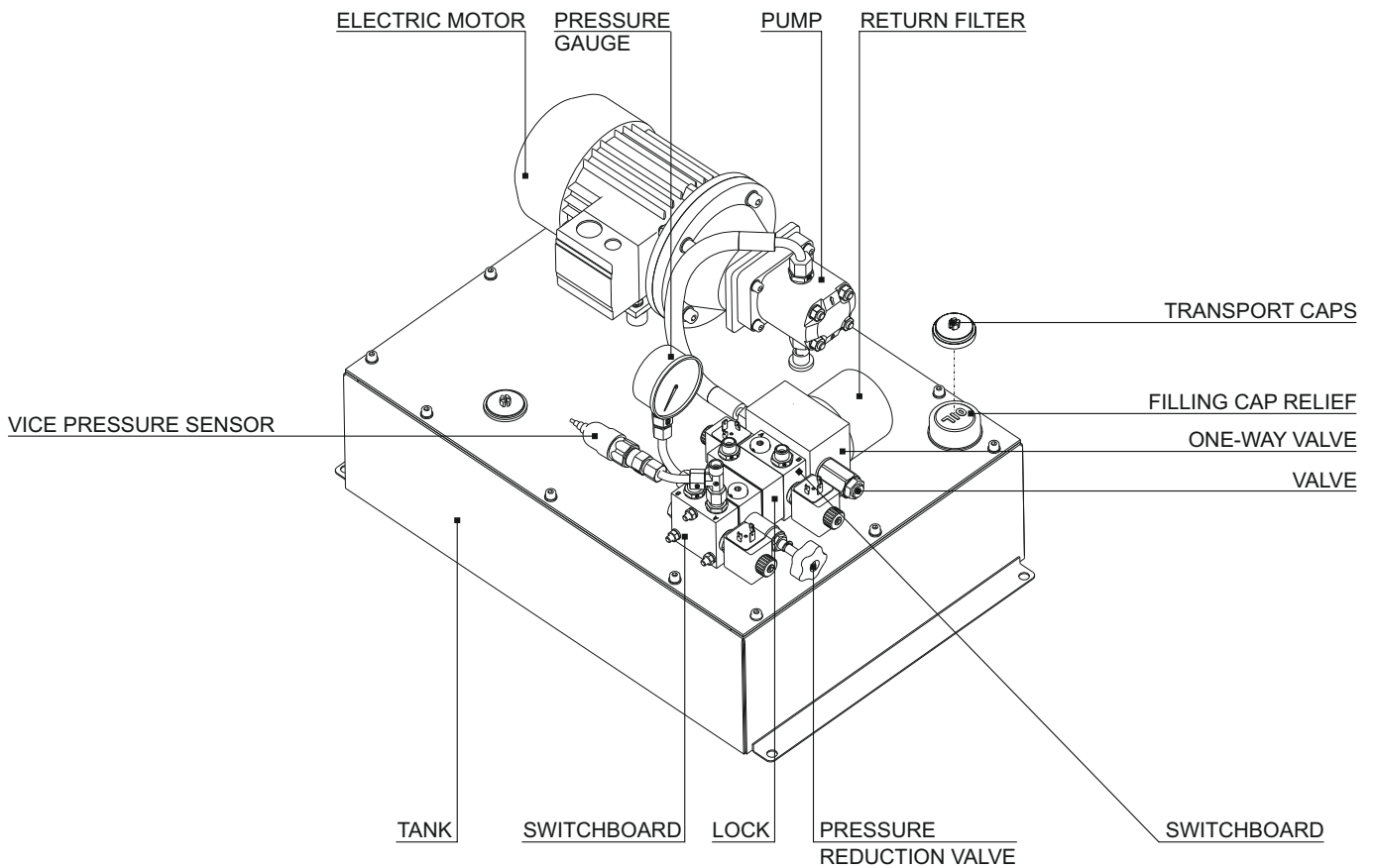

### 4.9.1. Vice Clamping Force Setting

The hydraulic unit is fitted with a PRESSURE REDUCTION VALVE. It enables setting the required vice clamping force depending on the kind of the workpiece within the range:

13-35 bar for ARG 330 S.A.F., ARG 330 plus S.A.F.,

15-30 bar for ARG 380 plus S.A.F., ARG 400 plus S.A.F., ARG 500 plus S.A.F. .

Turning the PRESSURE REDUCTION VALVE to the left reduces the pressure, while turning it to the right increases the pressure (see picture). The specified pressure is shown on the pressure gauge.

If the pressure is set below the clamping force smaller than 13 bar (for ARG 330 S.A.F., ARG 330 plus S.A.F.) or than 15 bar (for ARG 380 plus S.A.F., ARG 400 plus S.A.F., ARG 500 plus S.A.F.), the safety PRESSURE CONTROLLER will not switch on and the saw blade will not start.

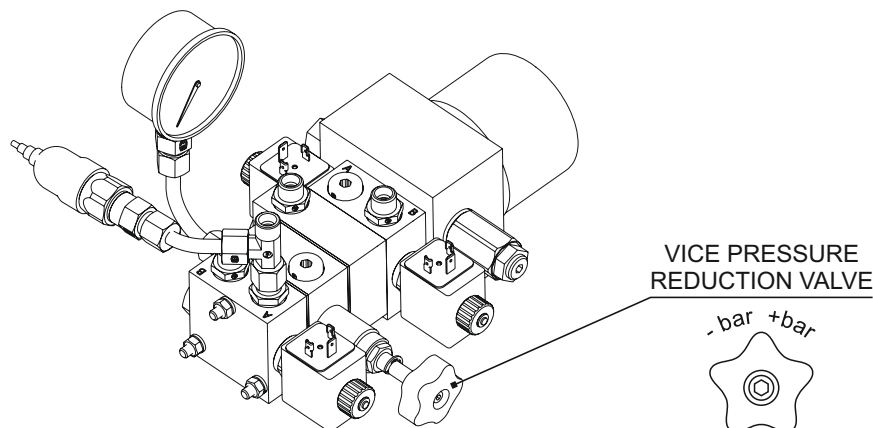



## 4.10. Cooling System

The pump and the coolant tank, which are mounted in the machine base, are the basic elements of the cooling system. The coolant pump conveys the coolant via hoses, valves and guide heads to the saw blade. The main cooling via the guide heads is complemented by an additional cooling system. The coolant quantity is regulated with valves. The coolant cools down and lubricates the saw blade and flushes away metal chips. The pump switches on and off when the saw blade drive is started or shut down. The pump can be started during the machine cleaning and also when the saw blade or the hydraulic unit are off. Activate the machine cleaning menu - chips conveyor and manually start the coolant pump.



If you fill too much coolant, an overflow resulting in spilling the coolant under the saw may occur.



When handling coolants, risks linked to hazardous substances cannot be avoided. Observe the manufacturer's and/or your company's instructions and recommendations referring to safe coolant handling.

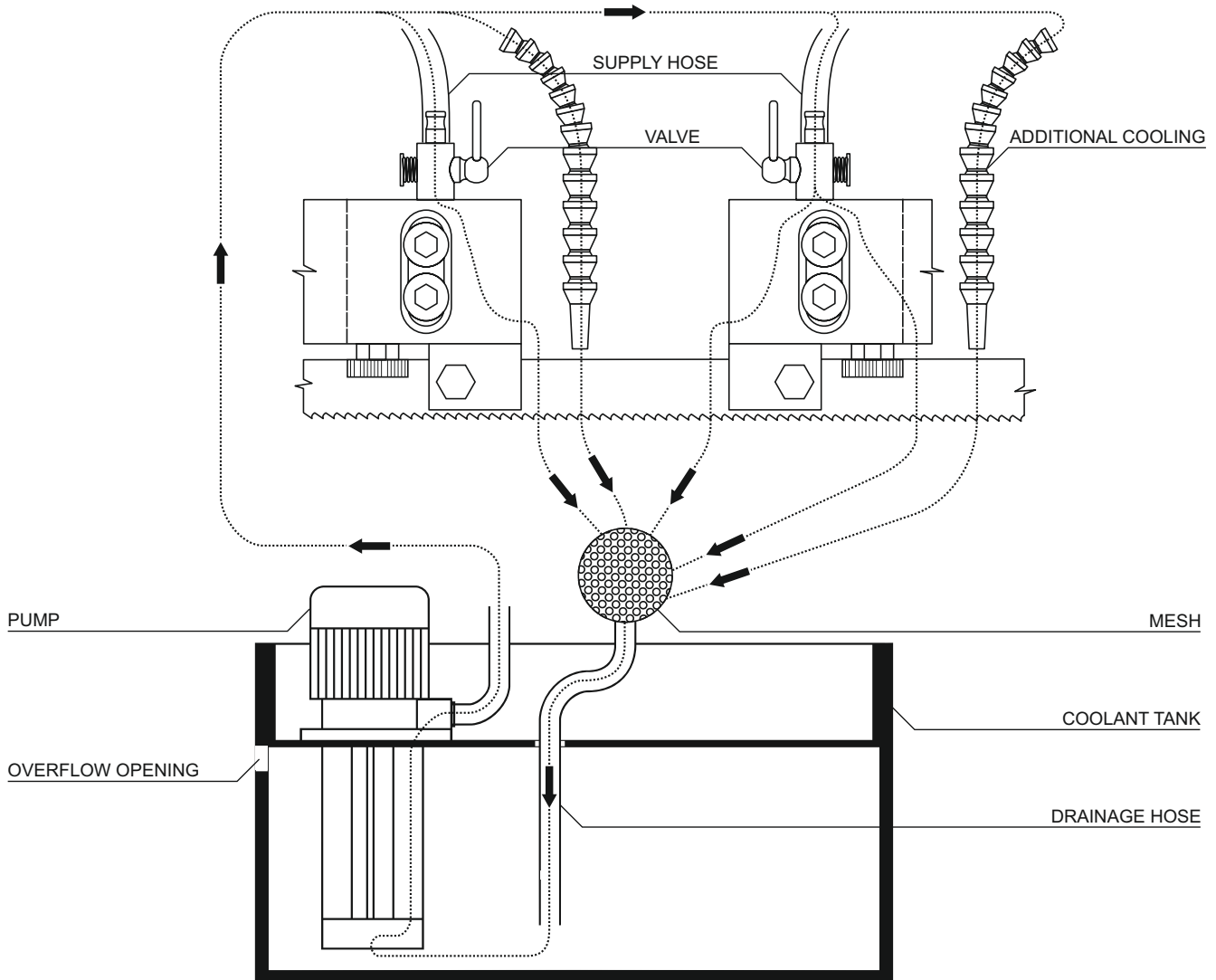

## 5. Commissioning

### 5.1. Security Check





Is everything in perfect condition with regard to safety and technical condition?  
Are all protective devices mounted properly?











### 5.2. Cutting Procedure





**Danger of injury!**  
**No cover on the saw blade in the cutting area!**  
**High risk of injury in the operating area of the blade!**

- 1) Release the arm in the band saw ARG 380, 400, 500 plus S.A.F. (see section 3.5.)
- 2) The TOTAL STOP button is unlocked. Turn on the POWERSWITCH. The operation system turns on the control panel display. A yellow screen will appear, showing: "Close the arm cover, unlock the TOTAL STOP and press the yellow-lit SAFETY button". Press the SAFETY button.
- 3) The MAIN MENU will initialize. Turn on the HYDRAULIC UNIT START 
- 4) Select the MANUAL MODE , or SEMI-AUTOMATIC MODE 

#### MANUAL MODE

- 5) You have selected the MANUAL MODE. 
- 6) Switch the saw arm end stroke switch to position 0. Keep raising the arm into the upper position  (see section 4.1. MANUAL MODE) so that the saw blade is above the cut material. Meanwhile, the display (see section 4.1. MANUAL MODE) shows the current position of the blade over the bearing surface. Stop the lifting.   
If the arm is unnecessarily high, bring the arm down  and control the descent speed by a control valve. Stop the descent  and shut off the CONTROL VALVE.
- 7) Open the vice  (see section 4.4.).
- 8) Insert the workpiece and set the desired cut length.
- 9) Clamp the vice. 
- 10) In ARG 330, move the movable bar in a way that allows moving the guide head towards the cut workpiece to the distance of 30-50 mm.
- 11) Make sure the control valve is closed.
- 12) Turn on the SAW BLADE START, which will start the saw blade. Set the desired saw blade speed by a SAW BLADE SPEED CONTROLLER.
- 13) Start the arm descent. 
- 14) Set the optimum arm descent to the cut speed by gradual loosening of the CONTROL VALVE and carry out the cutting.
- 15) Lift the arm into the upper position , or use the ARM END STROKE SWITCH 0->1.
- 16) Open the vice. 
- 17) Insert a new workpiece, or move the current one.

#### SEMI-AUTOMATIC MODE

- 5) You selected the SEMI-AUTOMATIC MODE
- 6) By editing the value, you set the height of the uplift into the upper position in order to bring the blade above the cut material. You can edit it repeatedly, but only as regards the upper position. The ARM STROKE LIMIT SWITCH must be in position 1.
- 7) Lock the CONTROL VALVE.
- 8) Open the vice. 
- 9) Insert the workpiece and set the desired cut length.
- 10) Clamp the vice.  Clamping the vice is not entirely necessary. If you clamp the workpiece and execute the cutting cycle, the cutting will be carried out and the workpiece will remain clamped. If you do not clamp the workpiece and execute the cutting cycle, the automatic workpiece clamping will occur and after the final cut, the vice will unclamp automatically.
- 11) In ARG 330, move the movable bar in a way that allows moving the guide head towards the cut workpiece to the distance of 30-50 mm.
- 12) Make sure the control valve is closed.
- 13) Start the cycle by the SAW BLADE START button to start both the saw blade and the arm descent (possibly also the workpiece clamping, see the point 10). Set the desired saw blade speed by a SAW BLADE SPEED CONTROLLER.
- 14) Set the optimum arm descent to the cut speed by gradual loosening of the CONTROL VALVE and carry out the cutting.
- 15) If you wish to keep the arm in the lower position after the cutting has been finished, switch the ARM END STROKE SWITCH into position 0 or into position 1, if you wish to move the arm into the upper position (adjustable height).
- 16) Insert a new workpiece, or move the current one.

## 6. Machine Maintenance



### **Danger of injury!**

**Carry out the maintenance work only if the power switch is off or if the machine is disconnected from the mains.**

Care and maintenance is absolutely necessary to maintain the functionality of the machine and its components. This includes: check and adjustment of band saw guide heads • cleaning • metal chips removal • removing metal chips from the internal part of the band saw arm • coolant replacement • lubrication of sliding surfaces and bearings • checking of supply lines for damage • vice checks • screw connection checks • limit switch checks



### **Check protective devices**

Check the protection devices for possible damages and faults prior to the start of everyday work.



### **Check power cable**

Check in regular intervals, at least once a week: integrity of electric installation • integrity of connections and relief from pulling

### 6.1. Cleaning

Clean the machine in regular intervals (always at the end of the shift, or if required, during the shift). Use suitable cleaning agents. Do not use solvents (e.g. nitro thinner). Do not use compressed air! Compressed air would blow delicate chips and dirt particles under sliding elements or endanger the health of personnel by flying particles.

### 6.2. Removal/disposal of chips



**Observe the instructions and recommendations concerning safe disposal of waste produced during operation.**

Correct cutting angles will be achieved when the bearing surfaces for the workpiece and the surfaces of gripping jaws are free from metal chips or other impurities.

### 6.3. Coolant system cleaning



**When handling coolants, risks linked to hazardous substances cannot be avoided. Observe the regulations and recommendations (operating instructions by professional associations or your company) related to safe handling of coolants.**

The coolant tank cannot be removed from the machine base during the maintenance and cleaning. Access to it is facilitated through the lid in the base.

**Caution: Used coolant belongs to special waste category!**

**Our recommendations:** Regular cleaning and maintenance of the coolant increases the service life and functionality of the coolant pump. If possible, use the coolants miscible with water, non-irritant to skin and with high protection against aging and corrosion. Check the volume of oil in the coolant at least once a week. Optimum lubrication increases cutting productivity. There is a barrier in the coolant tank that separates the space for filtering impurities. This space should be cleaned during routine checks depending on the kind of material to be cut.

### 6.4. Lubrication

Regular lubrication and cleaning extend the life and functionality of the machine. During a regular check, make sure that there is enough grease on the friction surfaces of the vice, movable bars, and the tensioning helix. In ARG 330, do not forget to grease the trapezoidal screw of the vice regularly. Observe lubrication of greasing points according to the lubrication plan for individual machines, approximately once in a month. The first lubrication with lithium soap-based grease class NGLI-2 is applied during the assembly.

### 6.4.1. Lubrication points in ARG 330 S.A.F., ARG 330 plus S.A.F.

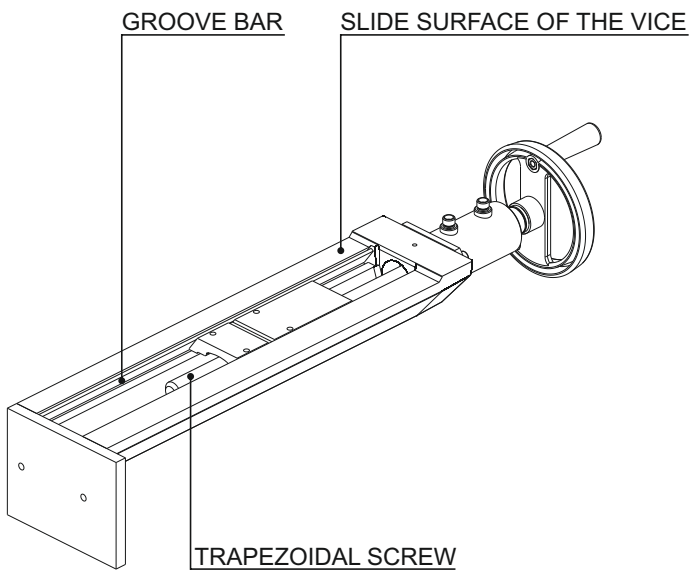
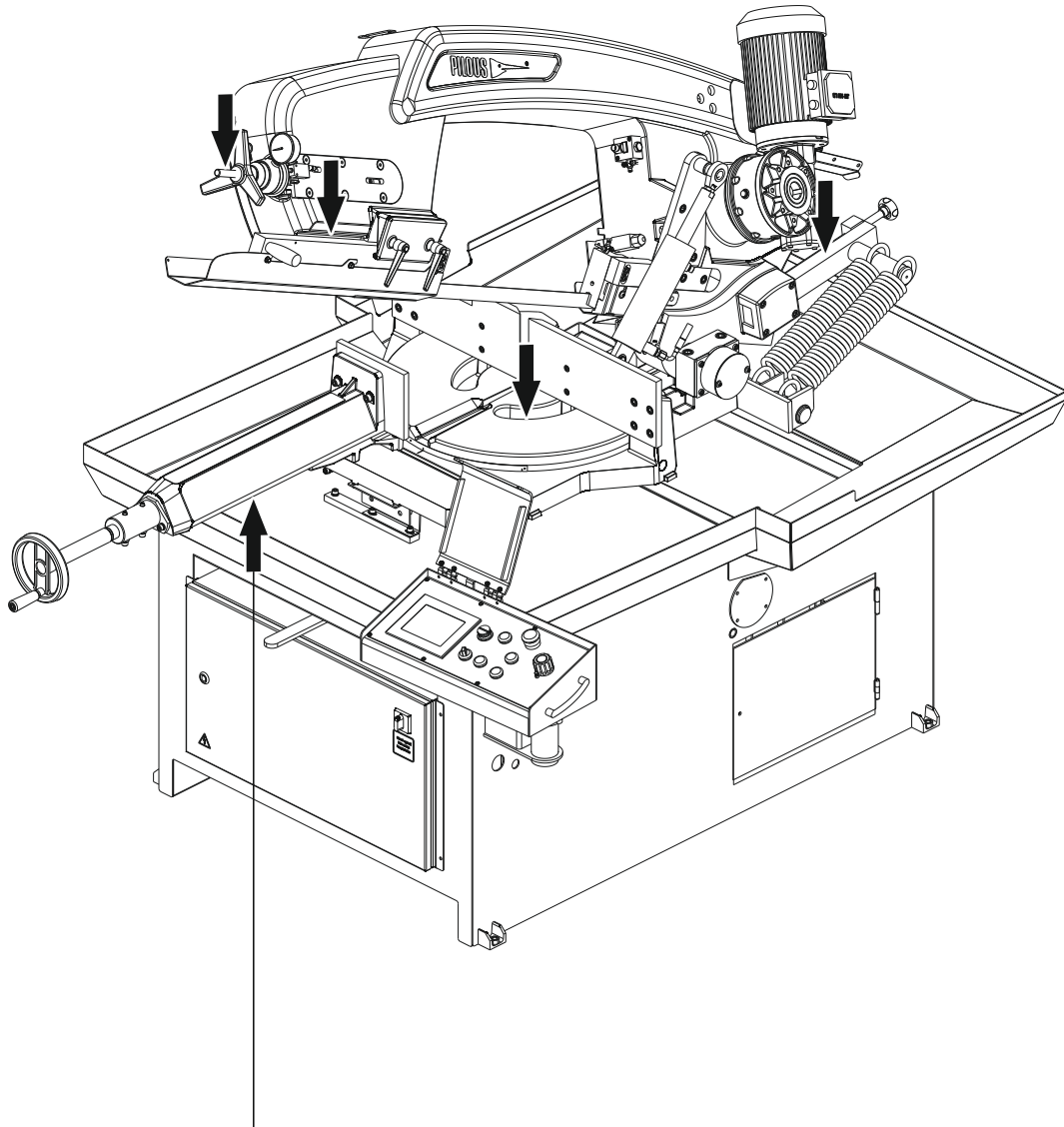

### 6.4.2. Lubrication points in ARG 400 plus S.A.F.

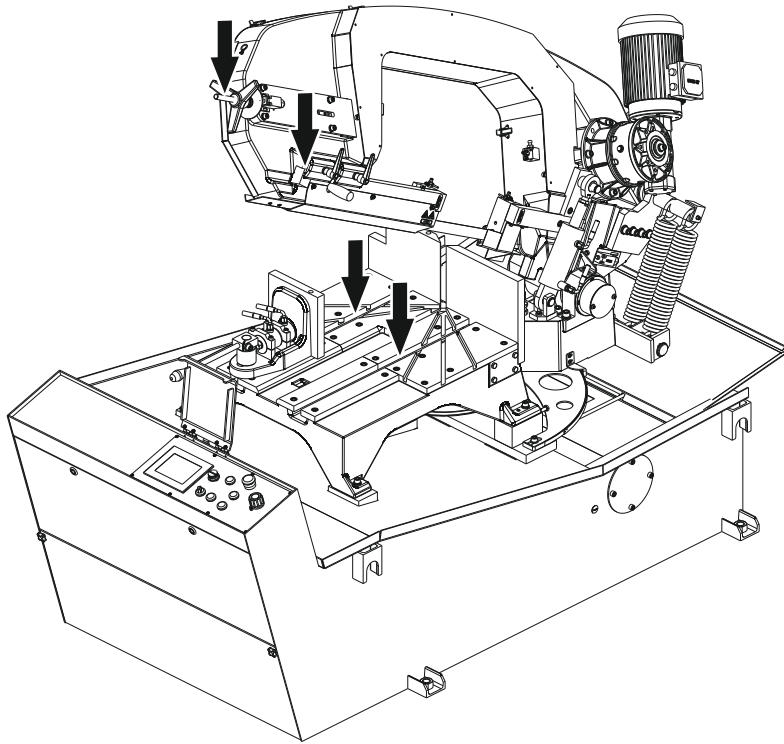

### 6.4.3. Lubrication points in ARG 380, 500 PLUS S.A.F.

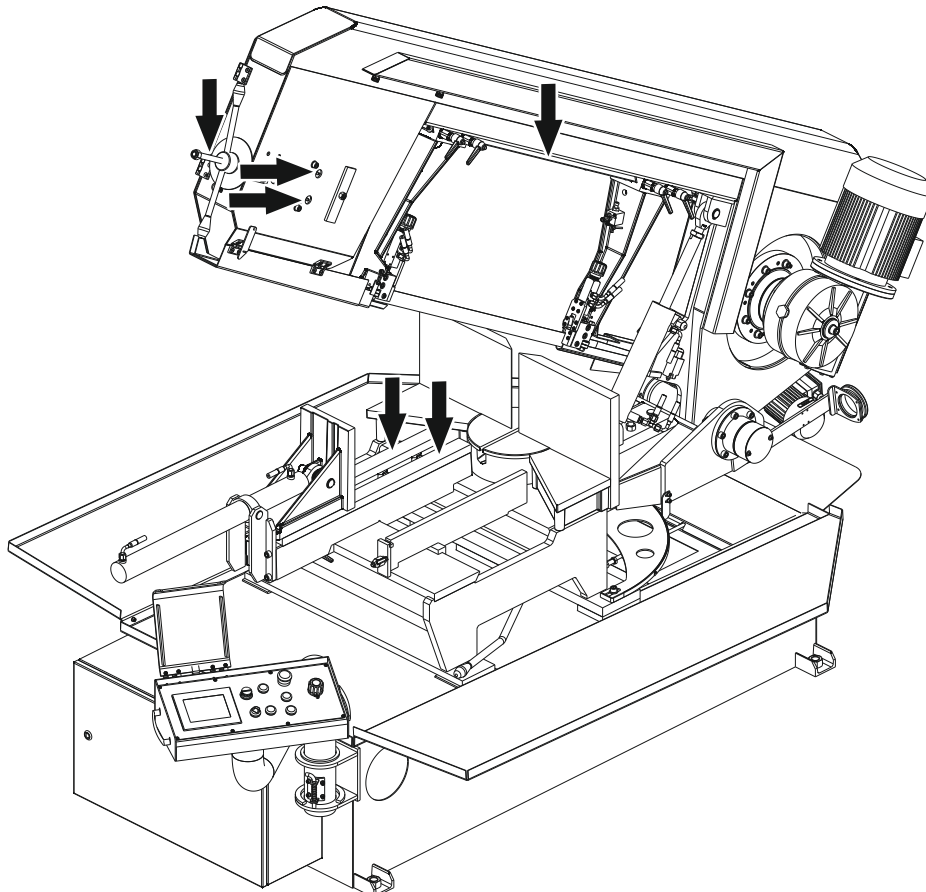

## 6.5. Principles of Hydraulic Unit Maintenance

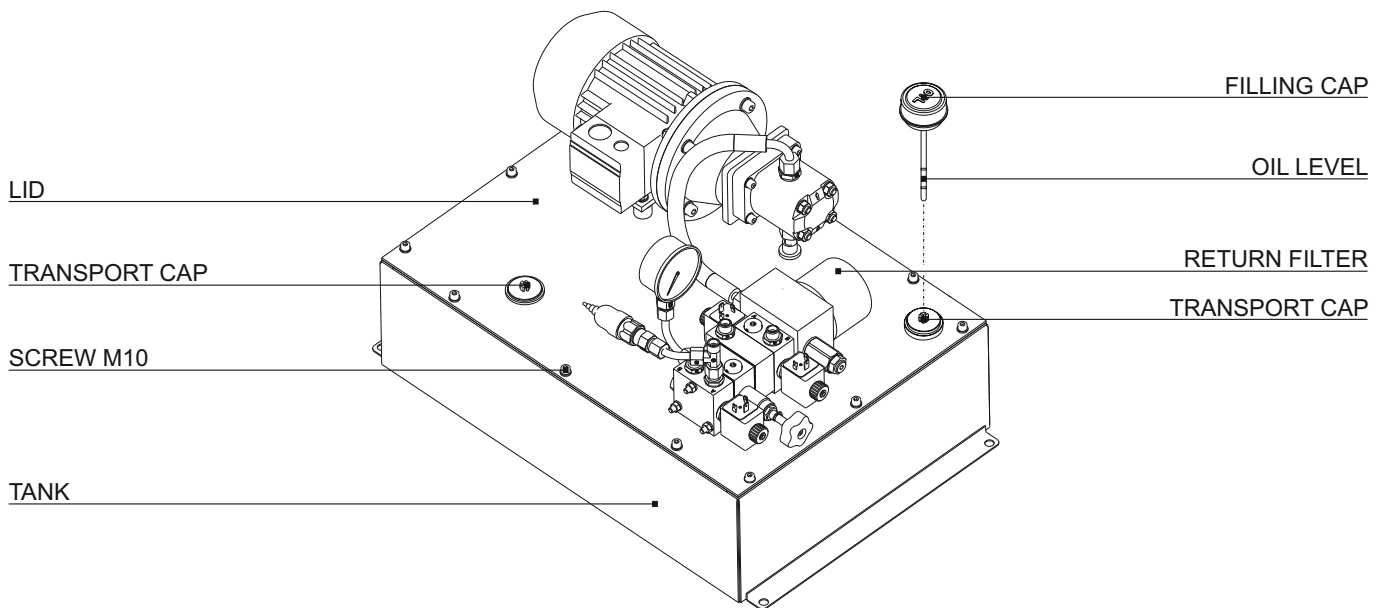

The following principles must be adhered to during the assembly of hydraulic circuit elements and piping. The basic rule in cleaning and maintenance is cleanliness and orderliness! The hydraulic circuit consists of very precise elements and it is very difficult, complicated and costly to remove any contamination and its consequences. Remove the protective cap just before putting the device into operation. Consistently check the oil level on the gauge located on the filling cap on the hydraulic unit.

### 6.5.1. Work safety

The hydraulic circuits are reliable and safe even when under high pressure, if all the elements are appropriately sized. However, a breakdown due to material defect or fatigue can occur in them, which could endanger the safety of the staff or contaminate the environment with oil. Examples of visible defects:

- **dripping oil;**
- **destruction of pressure-loaded circuit parts.**

Oil dripping from an untight connection or another spot, which collects on the floor, can cause slipping and falling of persons or floor damage and leakage to the environment, it can cause extensive pollution of large quantities of water. The destruction of pressure-loaded circuit parts does not lead to any explosion. If the crack is small, oil is dispersed to the environment in the form of mist, if the crack is large, mostly the whole tank will discharge. The destruction of pressure hoses will manifest itself by oil leaking, but very frequently also by bursting of hose socket. In such case, the hose can spring up and cause a serious injury. Both failures cause pollution of the environment and even a small spark can lead to a huge fire.

It follows that the following principles must be taken into account for installation and operation of hydraulic circuits:

- keep the machine clean, sprinkle the leaked oil with wood chips or VAPEX absorbate, sweep the floor, clean it with an appropriate solvent and dry;
- while dismantling, prevent oil spilling by installing suitable containers;
- units and all hydraulic elements including hoses and pipelines must be protected against external mechanical damage and heat resources;
- if the circuit is under pressure, do not come close to the pipelines and hoses, particularly do not expose your face;
- should oil be spilled into eyes, flush eyes with Optal or any other suitable agent immediately;
- if the anti-flaming agent is in eyes, seek medical help immediately.
- do not smoke or use open fire in the storage facility and near the units and hydromotors;
- shut down the hydrogenerator drive whenever you make any changes or repairs;
- electrical equipment must comply with ESC regulations;
- containers with industrial petrol may only be used in specifically designed spaces and must be covered with a cover or a closure at all times;
- hydromotors, which could start turning automatically in case that the driving hydrogenerator switches off (pressure drop), must be mechanically or hydraulically locked against this possibility;
- all hydraulic systems and circuits must be protected by a pressure valve against an overload, as well as hydromotors, which could become overloaded after hydraulic locking;
- the person responsible for maintenance and setting of the hydraulic unit must be appointed.

The aforementioned principles of safety at work are not exhaustive.

There are different conditions for each hydraulic circuit and different possibilities of endangering the environment. The aforementioned, however, should reduce the accident rate and improve the working conditions of users.

## 6.5.2. Commissioning

The hydraulic unit is fitted with two filling holes that are covered by red transport caps during the transport. The cap that is more accessible to the operator has to be removed and replaced by a filling cap with a gauge, otherwise a risk of making the entire system inoperable arises, along with the risk of pump damage. When transporting the hydraulic unit, always replace the filling cap with a gauge with a transport cap, see figure. Start the hydraulic unit within short intervals. Check the piping for noise and leakage. Vent the hydraulic circuit. Venting is performed usually by raising and descending the arm, clamping and unclamping the vice. Repeat several times, until the system is ventilated (usually 5-10 times).

## 6.5.3. Hydraulic Liquids

The correct function, service life, operational reliability and economy of the hydraulic equipment are substantially influenced by the usage of suitable hydraulic liquids. Mineral oils, also called hydraulic oils, are the most frequently used liquids. **Hydraulic liquids fulfil various tasks in the hydraulic equipment. The most important of them are the following:**

- hydraulic energy transfer from the hydrogenerator to the hydromotor
- lubrication of moving parts of hydraulic elements
- rust protection
- discharge of impurities
- water drain
- air vent, etc.
- removal of loss heat developed by volume losses and friction.

**The hydraulic liquid quality is specified by the following parameters:**

**Kinematic viscosity** is defined as a measure of internal friction of the fluid. Higher viscosity means a thicker liquid. The viscosity unit is  $m^2 \cdot s^{-1}$  ( $mm^2 \cdot s^{-1}$  is used in practice). Viscosity is dependent on temperature. The amount of temperature influence, i.e. the change of viscosity with temperature, is determined by the viscosity index. The bigger the viscosity index, the smaller the dependence of viscosity on temperature (in standard mineral oils between 85 and 90, in better quality oils 100 and higher).

**The compressibility** affects the rigidity of the system and thus also the precision of motion in high-pressure devices. The compression value is relatively small. The compressibility of liquid increases with the content of air or other gases.

**Foaming quality** is undesirable with regard to the function of liquid but also with regard to its ageing. Chemical additives reduce the foaming quality. The foaming quality can be very substantially affected by the hydraulic system design (tank design, air suction).

### Requirements for Liquid Properties

The main requirements can be put as follows:

- small dependence of viscosity on temperature change
- corresponding viscosity ensuring good efficiency of the system
- good lubricating capacity and high mechanical oil film stability
- chemical stability and neutrality against materials used
- operational stability (liquid resistance against ageing)
- low foaming quality
- availability and reasonable price.

### Specification of Hydraulic Liquids

HM and HV oil performance classes are particularly suitable for the use in hydraulic circuits.

**HM** - high-quality oils containing additives against oxidation, corrosion, foaming, for reducing wear and tear and viscosity modifier improving also low-temperature properties. They are intended for hydrostatical mechanisms with high mechanical heat stress and for machines operated in unprotected environment throughout the year.

**HV** - are highly refined oils with additives against oxidation, corrosion, foaming, for reducing wear and tear and a viscosity modifier. High-quality oils with outstanding oxidation stability and anti-abrasive properties, low foaming quality and good resistance against formation of permanent emulsion and has excellent viscosity temperature dependence. They are intended for similar purposes as HM class oils, but with increased requirement for a very low dependence of oil viscosity on temperature, particularly for HP mechanisms of mobile machines operated within a wide range of ambient temperatures.

### Biologically Degradable Liquids

Lubrication properties of environmentally-friendly liquids are as a rule identical to those of mineral oils. As regards the resistance against ageing and tolerance of liquids to construction materials, no generally valid knowledge is available at present. Usage of the liquid must be tested. Nevertheless, practical experience shows clearly that carefully adjusted systems operated with environmentally-friendly liquids run smoothly.

**Do not use any vegetable oils in the hydraulic unit. Risk of contamination of the whole system and irreversible damage to the unit!**

Oil type	Kinematic viscosity in $mm^2 \cdot s^{-1}$ at the temperature					Freezing point in $^{\circ}C$
	0 $^{\circ}C$	20 $^{\circ}C$	40 $^{\circ}C$	60 $^{\circ}C$	80 $^{\circ}C$	
MOGUL HM 32	220	100	32	15	8,5	-40
MOGUL HM 46	400	170	46	18	11	-30
MOGUL HV 32	180	67	32	17	11	-40
MOGUL HV 46	350	110	46	25	14	-36



## 6.5.4. Hydraulic Mineral Oils

HM performance class according to CETOP RP 91H European specification in viscosity classes ISO VG 32 and 46. Oils marked as HM 32 are recommended for use in environment with ambient temperatures reaching 0 °C and below 0 °C. HM 46 oil types are recommended for use in environment with ambient temperatures within the range +5 °C and +40 °C.

CETOP RP 91 H Specifications	HM 32	HM 46
AGIP	OSO 32	OSO 46
ARAL	VITAM GM 32	VITAM GF 46
BP	ENERGOL HLP 32	ENERGOL HLP 46
CASTROL	HYPIN AXS 32	HYPIN AWS 46
ESSO	NUTO H 32	NUTO H 46
MOBIL	MOBIL DTE 24	MOBIL DTE 25
MOGUL	MOGUL HM 32	MOGUL HM 46
OLEA	OPTIMA HM 32	OPTIMA HM 46
ÖMV	HLP 32	HLP 46
PARAMO	PARAMOL HM 32	PARAMOL HM 46
SHELL	TELLUS OIL 32	TELLUS OIL 46
VALVOLINE	ULTRAMAX AW 32	ULTRAMAX AW 46

## 6.5.5. Service intervals

The hydraulic unit is filled with OPTIMA HV46 hydraulic oil, for which it is recommended to replace the oil within a time interval shorter than 4,500 operating hours, along with the return filter, or once in a year depending on what occurs first. Replace the return filter each 1,500 operating hours (MANN FILTER W 79 supplied by the manufacturer). Consistently check the oil level on the gauge located on the filling cap on the hydraulic unit in the machine base. The oil level must be maintained between the two oil marks.

## 6.5.6. Oil Refill and Filter Replacement

- Unscrew the return oil filter.
- Remove the lid of the hydraulic unit by unscrewing the twelve M10 bolts.
- Very carefully raise the lid and make sure the sealing does not stick to the lid or the tank, leading to its damage.
- If the sealing is damaged, replace it for a new one. Never use a damaged sealing, otherwise you risk contamination of the hydraulic system by the remnants of cork sealing.
- When replacing the oil, pour out the old oil and clean the tank. A cloth is a sufficient tool for cleaning, but it must be non-linting. You can use a solution that does not disturb the tank coating and does not leave residues in the tank. After the cleaning, check the inside of the tank thoroughly. Check the condition of the oil-resistant coating. Should any flaking or poor quality manifest themselves, remove the coating with an appropriate solvent, wash, dry and clean with pressure air. In this way, failures caused by deteriorated coating, which contaminates the entire hydraulic system, will be prevented.
- Once the tank is clean and free from deposits, place the lid and the sealing back on the tank using a reverse procedure and cross-tighten the screws.
- Pour in new oil. Only oil recommended by the equipment manufacturer can be filled in. Never refill directly from barrels. Always use a filter unit with filters with a mesh density lower than 25 µm. Using filters with contamination indication improves the quality and convenience of the work. Consistently check the oil level on the gauge located on the filling cap. **The oil level must be maintained between the two oil marks.**
- Unscrew the new return oil filter.
- Check the piping for noise and leakage.
- Start the hydraulic unit within short intervals.
- Vent the hydraulic circuit. Venting is performed usually by raising and descending the arm, clamping and unclamping the vice. Repeat several times, until the system is ventilated (usually 5-10 times).

**Caution: Oil and the filter are classified as special waste!**

## 7. Faults and Remedies

### 7.1. Repairs



**Caution! Danger of injury!**

Carry out repairs only when the MAIN SWITCH is off or secured against switching on or when the machine is isolated from the power supply and secured against restarting. The saw arm must always be supported mechanically in the lower position while it is being repaired - see section 3.5. We recommend to contact an authorised service centre for repairs.

## 7.2. Failures - Potential Causes and Remedies

Failure	Possible cause	Remedy
Saw blade feed cannot start	<ul style="list-style-type: none"> <li>• The power switch is off</li> <li>• The TOTAL STOP button is locked.</li> <li>• The protective overcurrent relay is off</li> <li>• The vice is not clamped</li> <li>• The control board fuse is burnt</li> <li>• The saw arm is in the lowest position, the limit switch is pressed</li> <li>• The saw arm is not in upper position when in S.A.F. mode</li> </ul>	<ul style="list-style-type: none"> <li>• Turn on the power switch</li> <li>• Unlock the TOTAL STOP button</li> <li>• Check motor protective switch</li> <li>• Clamp the vice</li> <li>• Replace the fuse</li> <li>• The saw arm must be raised when the saw blade starts</li> <li>• The saw arm must be in the upper position when in automatic mode</li> </ul>
The motor is on, but the saw blade is not moving	<ul style="list-style-type: none"> <li>• The saw blade slips on the running wheel</li> <li>• Broken blade</li> <li>• Other fault in the gearbox</li> </ul>	<ul style="list-style-type: none"> <li>• Tension the blade properly as specified in section 4.7</li> <li>• Replace it (see section 4.7.)</li> <li>• Call the service technician</li> </ul>
Red light on the control panel		<ul style="list-style-type: none"> <li>• Control panel describes the type of fault</li> </ul>
Irregular cooling	<ul style="list-style-type: none"> <li>• Coolant used up</li> <li>• The coolant tank and/or supply pipes or the ball valves are contaminated</li> <li>• Broken pump</li> </ul>	<ul style="list-style-type: none"> <li>• Check the coolant</li> <li>• Clean the coolant tank and supply pipes</li> <li>• Replace the pump</li> </ul>
Vibration during cutting	<ul style="list-style-type: none"> <li>• The feed to cut occurs within a non-desirable range</li> <li>• Wrong selection of saw blade tooth size</li> <li>• Incorrectly adjusted guide heads, hardened steel blade guides, bearings</li> <li>• Incorrectly clamped material</li> </ul>	<ul style="list-style-type: none"> <li>• Set 5% less/more feed to cut</li> <li>• Check the tooth size</li> <li>• Adjust it, see section 4.8.</li> <li>• Check workpiece clamping</li> </ul>
Broken teeth stuck in the cutting channel in the workpiece		<ul style="list-style-type: none"> <li>• Do not cut into an old cutting channel with a new blade! Otherwise you damage the new blade with the first</li> </ul>
The blade cuts under	<ul style="list-style-type: none"> <li>• Blunt saw blade</li> <li>• Wrong selection of saw blade tooth size</li> <li>• Feed to cut is too quick</li> <li>• The blade slid under guide bearings</li> <li>• Clearance between hardened steel blade guides</li> <li>• The workpiece is not placed parallel with the vice loading surface</li> </ul>	<ul style="list-style-type: none"> <li>• Replace the blade</li> <li>• Check the tooth size, see section 8.2.</li> <li>• Adjust the feed</li> <li>• Insert the blade properly as specified in section 4.7.</li> <li>• Adjust it, see section 4.8.</li> </ul> <p>Align the roller conveyor, check workpiece clamping</p>
Saw blade cracking between teeth	<ul style="list-style-type: none"> <li>• Wrong selection of saw blade tooth size</li> <li>• Feed to cut is too quick</li> <li>• Incorrectly adjusted or damaged guidance through heads (blade guides, bearings)</li> <li>• The moving guide head is too far from the workpiece</li> <li>• Insufficient cooling</li> <li>• Incorrectly clamped workpiece while cutting</li> </ul>	<ul style="list-style-type: none"> <li>• Check the tooth size, see section 8.2.</li> <li>• Adjust the feed</li> <li>• Adjust (see section 4.8.) or replace them</li> <li>• Move it closer, see section 4.5.</li> <li>• Increase the coolant supply</li> <li>• Clamp the workpiece properly</li> </ul>
Saw blade cracking on the face	<ul style="list-style-type: none"> <li>• Saw blade incorrectly placed on wheels (runs into the fitting)</li> <li>• Wrong selection of saw blade tooth size</li> <li>• Feed to cut is too quick</li> <li>• Incorrectly adjusted or damaged guidance through heads (blade guides, bearings)</li> <li>• The moving guide head is too far from the workpiece</li> </ul>	<ul style="list-style-type: none"> <li>• Check, see section 4.7.</li> <li>• Check the tooth size, see section 8.2.</li> <li>• Adjust the feed</li> <li>• Adjust (see section 4.8.) or replace them</li> <li>• Move it closer, see section 4.5.</li> </ul>
The feed to cut is not constant, sinks	<ul style="list-style-type: none"> <li>• Not enough oil in hydraulics</li> </ul>	<ul style="list-style-type: none"> <li>• Call the authorised service centre</li> </ul>
The arm descends even when the relief valve is closed	<ul style="list-style-type: none"> <li>• Loosened M4 screw on control valve's wheel - turns loosely</li> <li>• Valve seat is worn out</li> <li>• Cylinder sealing is worn out</li> <li>• Valve failure (impurities)</li> </ul>	<ul style="list-style-type: none"> <li>• Tighten it</li> <li>• Tighten M4 lock screw, turn wheel approx. 10° to the left and tighten</li> <li>• Call the authorised service centre</li> <li>• Call the authorised service centre</li> </ul>
The arm does not ascend	<ul style="list-style-type: none"> <li>• The arm uplift switch is set to 0</li> <li>• The power switch is off</li> <li>• The TOTAL STOP button is locked</li> </ul>	<ul style="list-style-type: none"> <li>• Switch it to 1</li> <li>• Turn on the power switch</li> <li>• Unlock the TOTAL STOP button</li> </ul>

## Faults reported by the system

**FAILURE**  
**Frequency converter**  
**reports a fault**

0

After pushing the failure message, you switch to a screen on which you can reset the converter (if the failure is resettable)

Upon pressing the button , the frequency converter will reset.

If such attempt to reset the converter fails, the fault is unresettable and you have to switch the machine off by the power switch and leave it off for a few minutes. Then turn the machine on again.

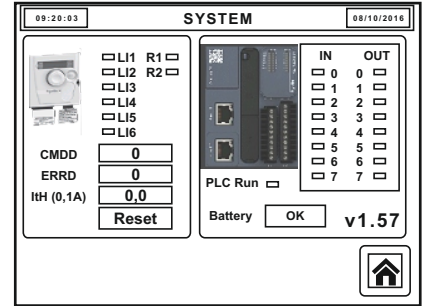

**FAILURE**  
**Blade-tension**  
**sensor**

In the event of insufficient tensioning of the saw blade or its breakage a failure message will appear.

Tension the saw blade (see section 4.7.), or replace the saw blade.

**Hydraulic failure**

Failure arises from the overload of the hydraulic pump. You can eliminate the failure by switching the motor switch FQ2 to position 1. If the failure arises repeatedly, check or replace the pump or motor switch. The motor actuator is placed in the switchboard in machine base.

**FAILURE IRC**

The screen indicates:  
Faulty arm position sensor.  
Arm stroke valve failure.  
Mechanical fault in the hydraulic unit.

**FAILURE TS**  
**Pressure sensor**

**Failure TS** - if the PLC loses signal from the pressure sensor during vice clamping, it will immediately pause and turn the hydraulic unit off. The hydraulic unit turns off because of the danger of leakage in the hydraulic system. Upon pressing the failures screen, a screen with settings appears on which you can check the operation of pressure sensors.

## 8. Saw Blades

### 8.1. Saw Blade Design

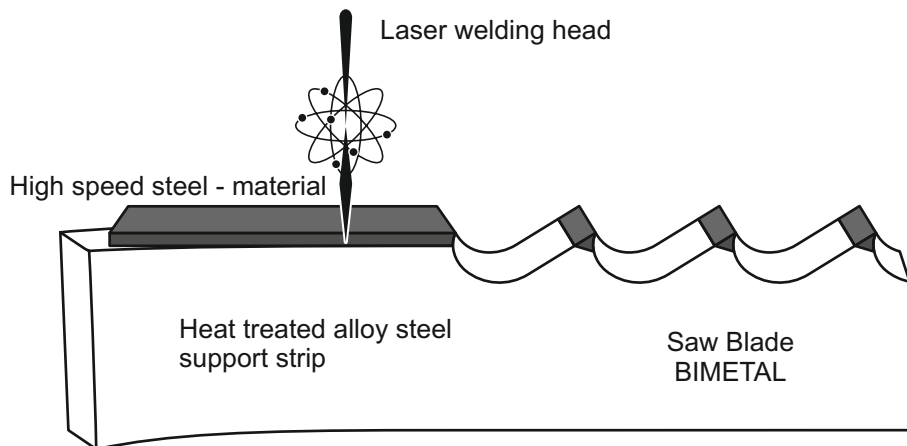

The prerequisite of the correct cutting power of the machine is the use of high-quality saw blades. In order to achieve a high cutting power, it is recommended to use bimetallic saw blades. The main saw blade component is a high-quality heat treated steel with a high elasticity limit. The tooth edges are high-speed steel of the following quality: M 42, M 51.

**M 42** - a saw blade for universal use for cutting metallic and non-ferrous materials within the whole range of quality classes up to the 45 HRC hardness. The saw blade is suitable for cutting full materials of all cross-sections and diameters, profiles, pipes and bundles.

**M 51** - in comparison to the M 42 saw blade, the M51 is designed first of all for cutting steel up to 50 HRC, steel of higher strength classes, acid-resistant and stainless steels. Furthermore, for cutting nickel, titan alloys and special grade of bronze.

**Carbide** - high cutting power as compared to bimetallic saw blades. Suitable for cutting of steel, non-ferrous metals, material with high content of chrome, nickel, titan, stainless steel and face-hardened materials up to 62 HRC. The saw blades can be used for all materials including stainless steel, tool steel, non-ferrous metals, cast iron, plastics and fibreboards. Characteristics of these saw blades include a high thermal conductivity, high wear and tear resistance and thus longer life, higher cutting speed, less frequent saw blade replacements and better productivity as compared with carbon steel saw blades.

Design: M 42 - composition: W 2%, Mo 10%, V 1%, CO 8%, tooth hardness: 68 HRC. For cutting of materials up to 45 HRC

Design: M 51 - composition: W 10%, Mo 4%, V 3%, Co 10%, tooth hardness: 69 HRC. For cutting of materials up to 50 HRC

Design: Carbide - tooth hardness 1600 HV. For cutting of materials up to 62 HRC.

In addition to standard shapes and sizes of teeth, the saw blades are also manufactured with special features, such as saw setting, tooth angle and tooth face shape, which are used particularly for cutting of specific materials. Please contact your saw blade supplier to get more information about these features.

#### Saw Blade Tooth Arrangement

a) **Constant** - tooth edge spacing always equal

b) **Variable** - the tooth edge space is different, repeating periodically. This modern saw blade design enables a bigger cutting range in one saw blade type. It is able to eliminate vibrations caused by the tooth edge touching the material and thus to achieve a clean smooth cut and longer service life.

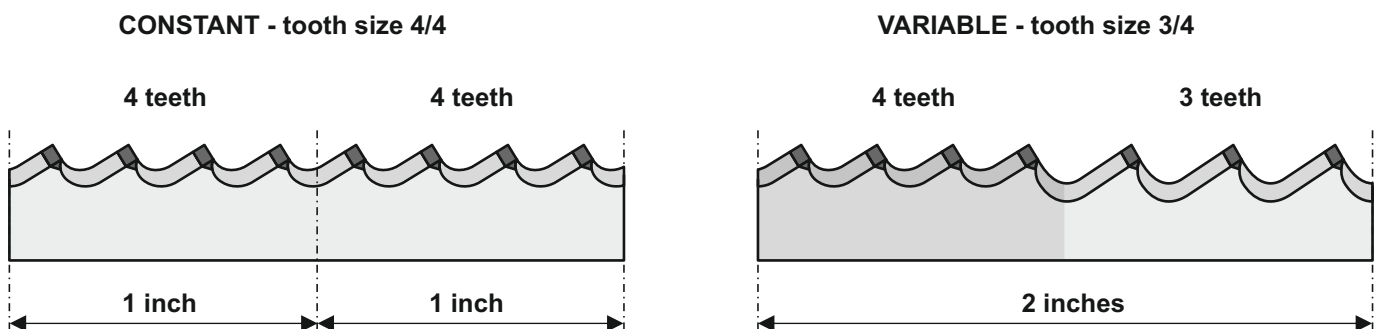

## 8.2. Selection of Tooth Size

The selection of the tooth size is of crucial importance for the saw blade service life.

### Tooth sizes recommended for cutting full materials

		ARG 330 S.A.F., ARG 380 plus S.A.F., ARG 400 plus S.A.F., saw blade 34x1,1			ARG 500 plus S.A.F. saw blade 41x1,3		
Material cross-section	Number of teeth per inch	Tooth quality M42/67-69 Hrc	Tooth quality M51/69 Hrc	Carbide 1600 Hr	Tooth quality M42/67-69 Hrc	Tooth quality M51/69 Hrc	Carbide 1600 Hr
0-10	14z	●					
0-25	10/14	●					
20-40	8/12	●					
20-40	8/11						
30-60	6/10	●			●		
40-70	5/8	●			●		
40-70	5/7	●					
60-110	4/6	●	●		●		
80-120	4z						
90-140	3/4	●	●	●	●	●	●
120-200	3z						
120-350	2/3z	●	●	●	●	●	●
200-400	2z						
250-550	1,4/2	●		●	●	●	●

The following table refers to piece-by-piece cutting of sectional materials. If the material is cut in bundles, the forces of the walls of individual tubes must be added with regard to their diameters.

### Tooth sizes recommended for cutting sections

Wall width mm	External tube diameter D (mm)												
	20	40	60	80	100	120	150	200	300	400	500	600	700
2	14	14	14	14	14	14	10/14	10/14	8/11,8/12	8/11,8/12	6/10	6/10	5/7,5/8
3	14	14	14	10/14	10/14	10/14	8/11,8/12	8/11,8/12	6/10	6/10	6/10	5/7,5/8	5/7,5/8
4	14	14	10/14	10/14	8/11,8/12	8/11,8/12	6/10	6/10	5/7,5/8	5/7,5/8	5/7,5/8	4/6	4/6
5	14	10/14	10/14	8/11,8/12	8/11,8/12	6/10	6/10	5/7,5/8	5/7,5/8	4/6	4/6	4/6	4/6
6	14	10/14	8/11,8/12	8/11,8/12	6/10	6/10	5/7,5/8	5/7,5/8	4/6	4/6	4/6	4/6	3/4
8	14	8/11,8/12	6/10	6/10	5/7,5/8	5/7,5/8	5/7,5/8	4/6	4/6	4/6	4/6	3/4	3/4
10		6/10	6/10	5/7,5/8	5/7,5/8	5/7,5/8	4/6	4/6	4/6	3/4	3/4	3/4	2/3
12		6/10	5/7,5/8	5/7,5/8	4/6	4/6	4/6	4/6	3/4	3/4	3/4	2/3	2/3
15				4/6	4/6	4/6	4/6	4/6	3/4	3/4	2/3	2/3	2/3
20				4/6	4/6	4/6	4/6	3/4	3/4	2/3	2/3	2/3	2/3
30				4/6	4/6	4/6	3/4	3/4	2/3	2/3	2/3	2/3	2/3
50						3/4	3/4	2/3	2/3	2/3	2/3	1,4/2	1,4/2
75								2/3	2/3	2/3	1,4/2	1,4/2	1,4/2
100									2/3	2/3	1,4/2	1,4/2	1,4/2
150									1,4/2	1,4/2	0,75/1,25	0,75/1,25	0,75/1,25
200											0,75/1,25	0,75/1,25	0,75/1,25
250											0,75/1,25	0,75/1,25	0,75/1,25
300												0,75/1,25	0,75/1,25

**Caution:** The aforementioned values do not apply to cutting of different sectional materials. Such a requirement must be treated with respect to the shape of the sectional material, the number of pieces in the bundle and the dimensions. When the saw blade is used for cutting sectional materials, its service life will decrease by up to one third due to interrupted cutting.

**Rule:** At least four, but not more than thirty teeth must cut in while a workpiece is being cut.

### 8.3. Optimum workpiece clamping

Correct workpiece clamping can significantly influence the service life of the saw blade and the cutting accuracy. Moreover, it allows for correct selection of tooth size. To cut material in bundles, we recommend to use upper (vertical) pressure device. In order to achieve the optimum cut (service life and cutting performance), observe these ways of clamping.

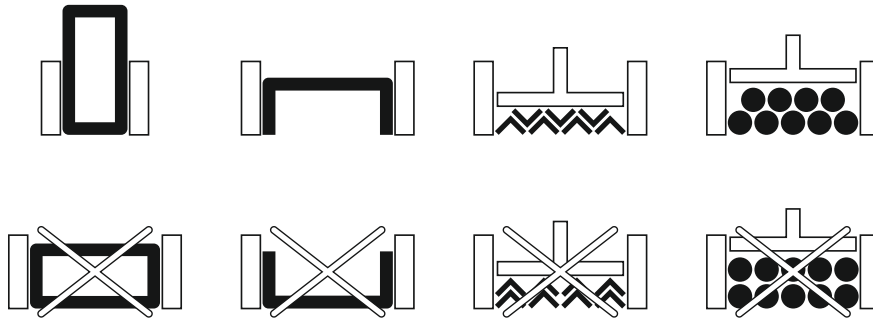

### 8.4. Running-in New Saw Blades

The running-in applies to new saw blades. The sharp cutting edges with extremely small edge radii enable high cutting power. In order to achieve maximum tool service life, you have to run in (optimum) the new saw blade. Given the correct cutting speed, the workpiece feed and the quality of its material, the saw blade must be run in only with 50% of currently used feed. Such measure will help you prevent breaking extremely sharp edges particularly in big workpiece sections. These micro-fragments cause destruction of other teeth. Should vibrations or noise due to oscillations manifest themselves when a new saw blade has been fitted, reduce the cutting speed slightly. In small workpiece sections it is recommended to run in the saw blade with a reduced power for 15 minutes, in big sections for 30 minutes. Then increase the feed slowly to the optimum value.

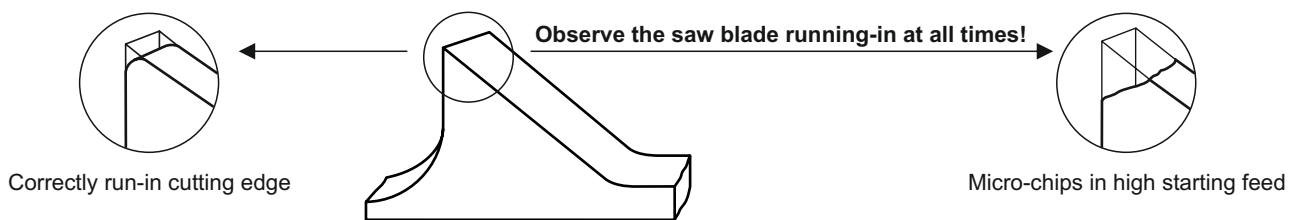

### 8.5. Factors Influencing Saw Blade Service Life

Inappropriate saw blade tooth size • inappropriate saw blade speed and saw blade descent speed to the cutting position • the saw blade (the whole band saw arm) leans against the workpiece when the band saw is not in the cutting position • the workpiece is not clamped as recommended • saw blade tension is not correct (mostly too little tension) • the saw blade is not correctly fitted on the wheels (the saw blade touches the wheel shoulder) • the saw blade guide heads are not correctly adjusted • the distance between the saw blade guide heads and the workpiece is too big • the oil content of the coolant is too low • the saw blade is not correctly run in • saw blade maintenance is insufficient, metal chips have not been removed from the band saw.



**The above mentioned faults lead to inaccurate cut, reduction of the saw blade service life and/or its destruction.**

### 8.6. Values Recommended for Cutting

The selection of values depends on the material class and the material section. The data in the table are only illustrative; they have to be adjusted to the material for certain ranges. The numbers of the CSN-Standards serve for information only. They define only the guide for the material properties for which the respective saw blade type is designed.

Material		Recommended blade speed (m/min)		Arm descent speed into the cut (mm/min)		Cooling oil volume (%)
ČSN	In general	ø 0-100 mm	ø 100-330 mm	ø 0-100 mm	ø 100-330 mm	
11 107 - 11 110	Free-cutting steel	70-90	70-90	190-60	55-20	10-15
11 301 - 11 420 / 12 010 - 12 020	Structure/construction steel	60-90	60-80	190-60	55-30	10-15
11 500 - 11 600 / 12 020 - 12 060	Cementing steel	60-90	50-70	125-38	35-25	10-15
13 250 / 14 260 / 15 260	Spring steel	50-70	40-60	125-30	28-15	5-10
14 100 / 15 220	Bearing steel	50-70	30-60	125-30	28-15	3
14 220 / 15 124	Alloy steel	50-80	40-70	125-35	30-20	10
17 020 - 17 042	NIRO steel	40-50	30-40	75-15	12-4	10-15
17 115	Valve steel	40-60	30-50	90-23	21-10	3
17 253 - 17 255	Heat-resistant steel	30-40	30	40-7	6-1	15
19 063 - 19 083 / 15 142 / 16 142	Refining steel	60-90	40-70	125-35	30-25	5-10
19 150 / 19 192 - 19 312	Non-alloy tool steel	50-70	30-60	120-25	20-8	5-10
19 422 / 19 452 / 19 721 / 19 740	Alloy steel	40-50	30-50	100-20	18-2	5-10
19 436	Hammer steel	30-40	30-40	62-15	14-5	do not
19 662	Nitriding steel	40-50	30-40	76-25	23-12	5
19 721	Tool steel for hot processing	30-40	30	70-1	16-6	5
19 802 - 19 860	High speed steel	40-60	30-50	90-23	21-10	3
INCONEL, HASELLOY, NIMONIC, INCOLOY		30	30	25-5	4-2	15-20
Heat-treated steel		30	30	25-5	4-2	15-20
Cast steel		30-70	30-60	190-60	55-25	40
Grey cast iron		40-80	30-70	190-60	55-30	do not
Copper, bronze, tin bronze		70-90	60-90	300-90	85-55	3
Red bronze		70-90	60-90	230-75	70-45	10
Aluminium bronze		40-70	30-60	230-75	70-45	10-15
Aluminium alloy castings		80-90	80-90	450-150	140-55	25
Al 99%, thermoplastics, plastics		50-90	50-80	450-150	140-55	do not

## 9. Nameplate

	<b>PILOUS</b> 		
MANUFACTURER	Producer Pilous-pásové pily, spol. s r.o.		EAC CE
MANUFACTURER'S ADDRESS	Address Železná 9, 619 00 Brno, CZ		
MACHINE MODEL	Model ARG 250 plus S.A.F.	Year	2016
SERIAL NUMBER	Serial No. 17/16/0067	kg	550kg
TOTAL WATTAGE	P 2.7kW	I	6.2A
OPERATING VOLTAGE	U 3x400V/50Hz		400/24
SAW BLADE SIZE	Blade 2710x27x0,9		
VOLUMETRIC FLOW	 4,7 dm <sup>3</sup> /min	p <sub>max</sub>	6 MPa

YEAR OF MANUFACTURE  
MACHINE WEIGHT  
RATED CURRENT  
CONTROL VOLTAGE  
MAXIMUM SYSTEM PRESSURE

The data are only illustrative



# 10. Electrical Wiring Diagram

v 19.4.2015

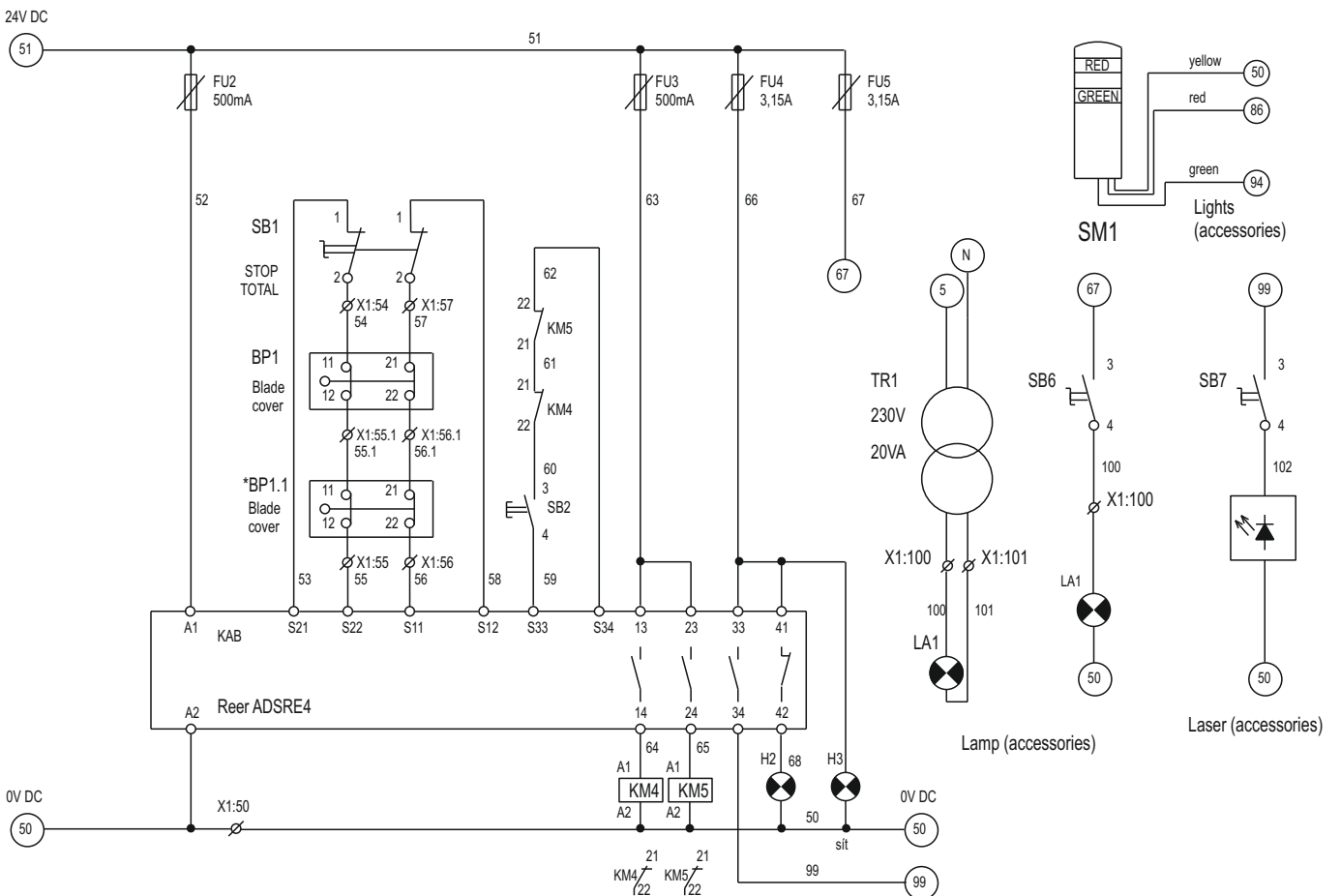
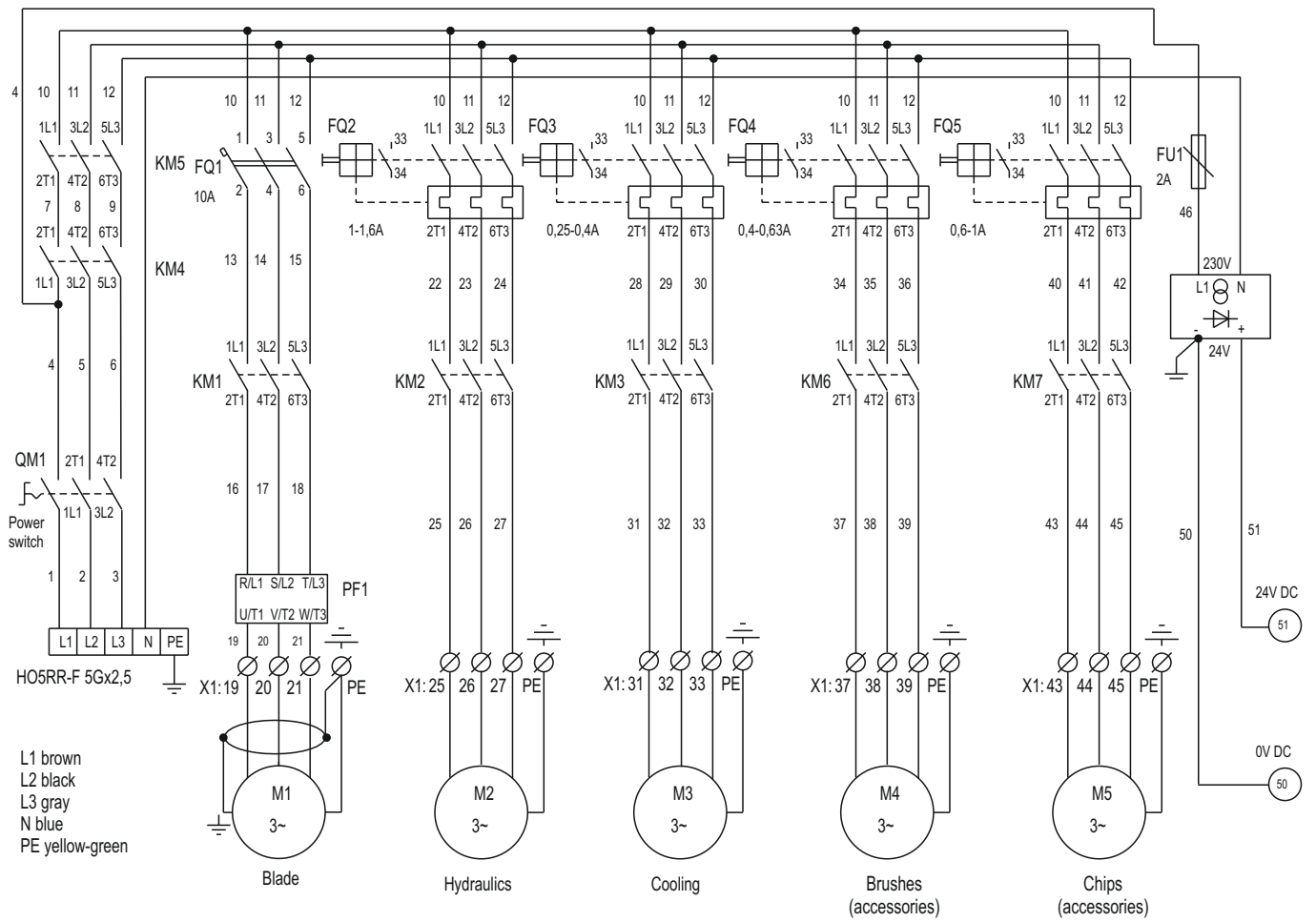

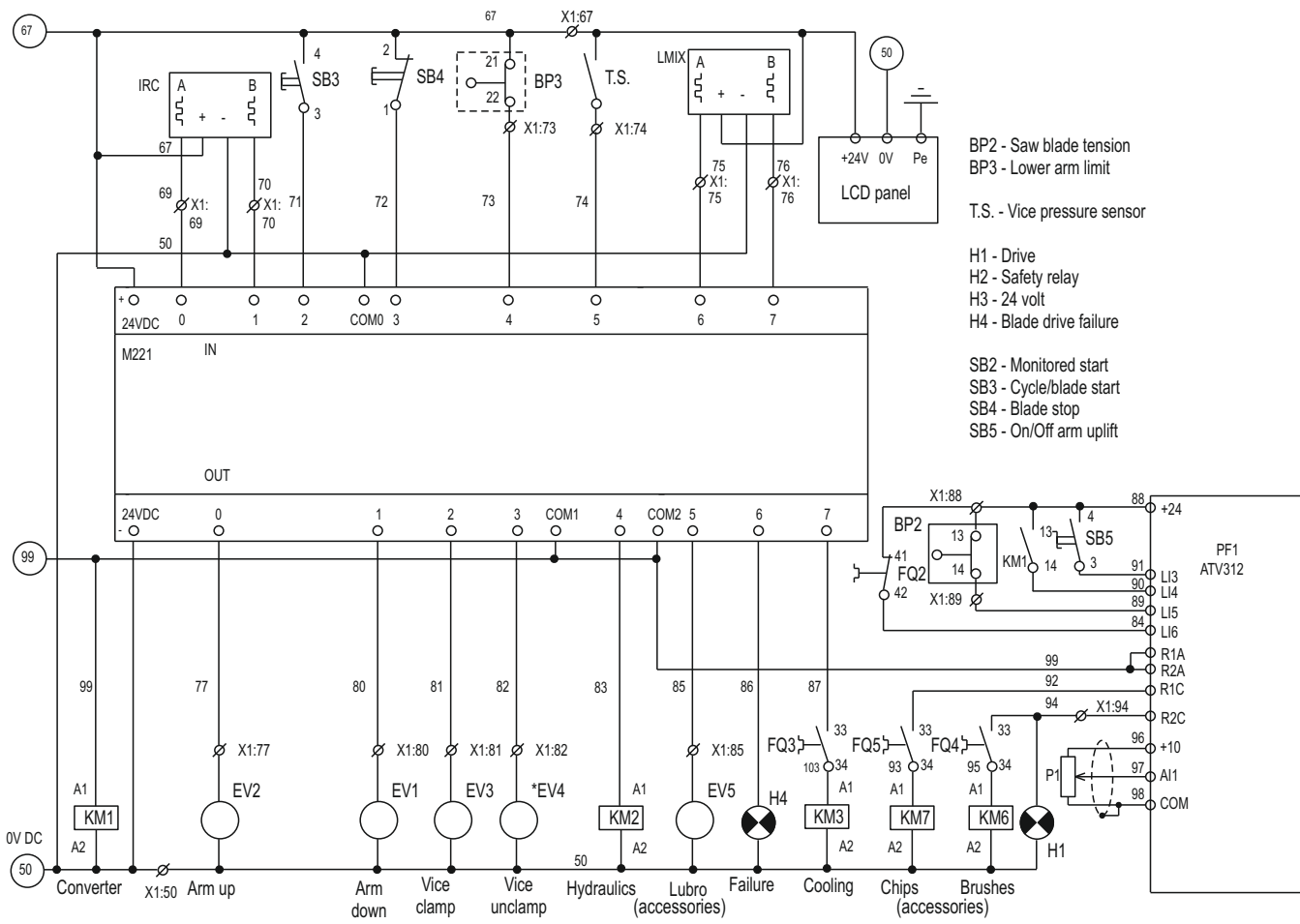

BP2 - Saw blade tension  
 BP3 - Lower arm limit  
 T.S. - Vice pressure sensor

H1 - Drive  
 H2 - Safety relay  
 H3 - 24 volt  
 H4 - Blade drive failure

SB2 - Monitored start  
 SB3 - Cycle/blade start  
 SB4 - Blade stop  
 SB5 - On/Off arm uplift

PF1  
 ATV312

Diagram:	Name:	Type:	Order No:
BP1	End switch Blade cover	FR 993	016830
BP1.1	End switch Blade cover	FR 993	016830
BP2	*End switch blade tensioning	FR 615	002491
	*End switch blade tensioning	PZ-NFB110BB-DN7	020687
BP3	Lower position limit switch	FR 6A1	002490
KM1	Contactora	DILEM - 10 (24V DC)	012488
KM2	Contactora	DILEM - 10 (24V DC)	012488
KM3	Contactora	DILEM - 10 (24V DC)	012488
KM4	Contactora	DILEM - 01(24V DC)	016828
KM5	Contactora	DILEM - 01(24V DC)	016828
KM6	Contactora	DILEM - 10 (24V DC)	012488
KM7	Contactora	DILEM - 10 (24V DC)	012488
FQ1	Circuit breaker	PL6-C10/3	017351
FQ2	Motor actuator	MS 325 + HKF11 1,0-1,6A	001921
FQ3	Motor actuator	MS 325 + HKF11 0,25-0,4A	001871
FQ4	Motor actuator	MS 325 + HKF11 0,4-0,63A	002702
FQ5	Motor actuator	MS 325 + HKF11 0,6-1A	021178
FU1	The fuse holder	Fuse terminal 5x20 tiltable	001779
	Fuse glass	2A	001597
FU2	The fuse holder	Fuse terminal 5x20 tiltable	001779
	Fuse glass	500mA	004197
FU3	The fuse holder	Fuse terminal 5x20 tiltable	001779
	Fuse glass	500mA	004197
FU4	The fuse holder	Fuse terminal 5x20 tiltable	001779
	Fuse glass	3,15A	001793
FU5	The fuse holder	Fuse terminal 5x20 tiltable	001779
	Fuse glass	3,15A	001793
zdroj	Actuated power unit	S8VK-C12024	020201
M221	PLC	TM221M16R	021462
LCD	Touch panel	HMIGTO2300	021461
KAB	safety relay	Reer AD SRE4	018630
PF1	*frequency converter 2,2kW	ATV312HU22N4	021015
	*frequency converter 4kW	ATV312HU40N4	021016
IRC	*Height sensor	15-62-0500-06,0	021126
	*Height sensor	LMIX22-012-12,0-2N50	021848
LMIX	Angle sensor	LMIX2-026-08,0-1-00	016693
P1	Potentiometer	TP195 4K7/N	002780
	Machine button	dia. 34,8mm	002781
SA2	MO rotary head, black 0-1	M22-WKV	006102
	MO head connection	M22-A	006103
	MO switch, unit 1on	M22-K10	006090
SB1	MO head lock Red	M22-PV/K01	006104
SB2	MO head grip.yellow-lit	M22-DL-Y	016736
	MO head connection	M22-A	006103
	MO switch, unit 1on	M22-K10	006090
H2	MO led socket white	M22-LED-W	006092
SB3	MO head grip.green-lit	M22-DL-G	006098
	MO head connection	M22-A	006103
	MO switch, unit 1on	M22-K10	006090
H1	MO led socket green	M22-LED-G	006094
SB4	MO head grip.red-lit	M22-DL-R	017172
	MO head connection	M22-A	006103
	MO switch, unit 1off	M22-K01	006091
H4	MO led socket red	M22-LED-R	006093
SB5	MO rotary head, black 0-1	M22-WKV	006102
	MO head connection	M22-A	006103
	MO switch, unit 1on	M22-K10	006090
H3	MO head sig. white	M22-L-W	006095
	MO head connection	M22-A	006103
	MO led socket white	M22-LED-W	006092
QM1	Switch	OT 16 ET3	002861
	OT switch - accessories	OTS 32 T 3	002863
	OT switch - accessories	OHB2PJ	003523
EV1	Electromagnet connector	is part of the hydraulic unit	005433
EV2	Electromagnet connector	is part of the hydraulic unit	005433
EV3	Electromagnet connector	is part of the hydraulic unit	005433
EV4	Electromagnet connector	is part of the hydraulic unit	005433
T.S.	Pressure switch	is part of the hydraulic unit	009150

# 11. Hydraulic Unit Wiring Diagram

## 11.1. Hydraulic Unit Wiring Diagram for ARG 330 S.A.F., ARG 330 plus S.A.F., ARG 400 plus S.A.F.

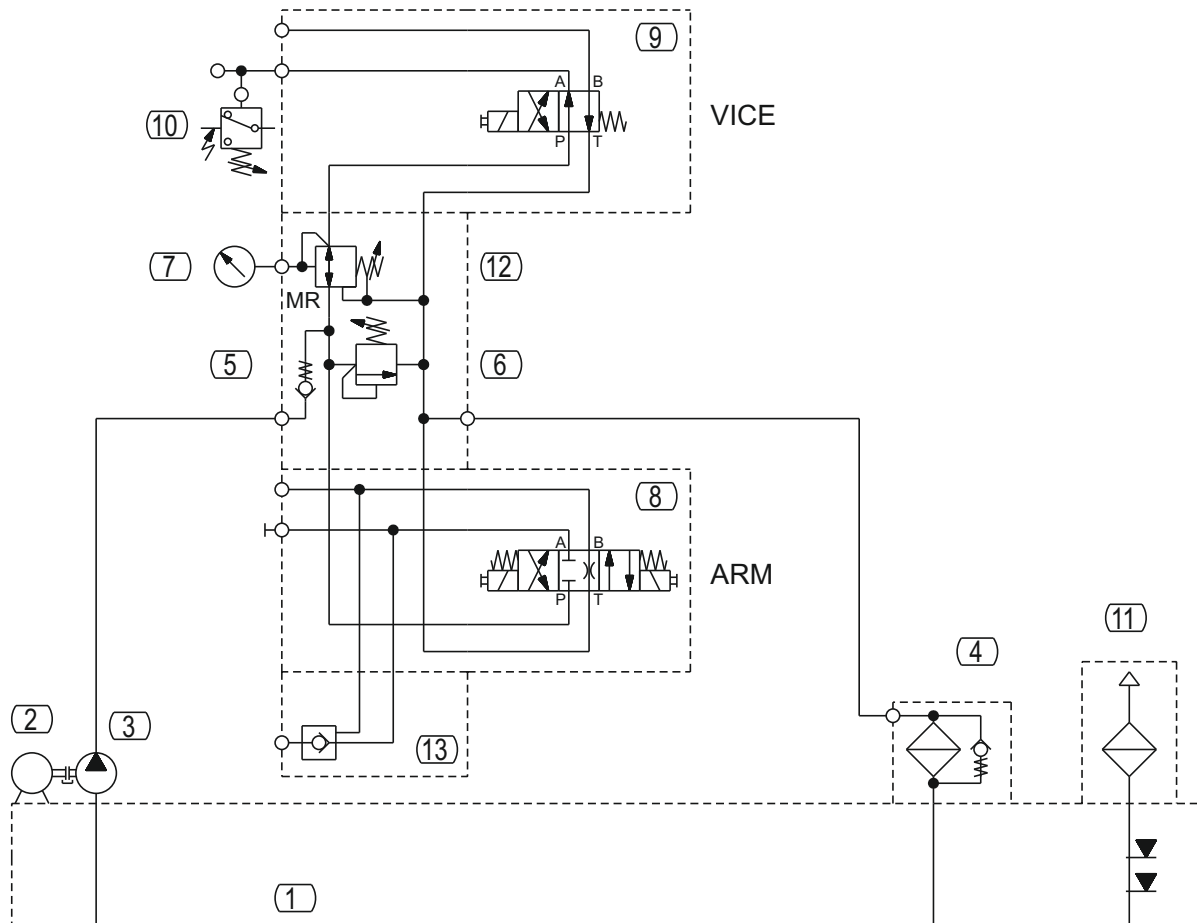

Q = 4,7 l/min

$p_{max}$  = 40 bar

P = 0,55 kW

UNIT TYPE NUMBER: S\_001\_200

UNIT CATALOGUE NUMBER:

POWER SUPPLY - BASIC PARAMETERS

Pos.	Name	Type identification
1	Tank	TM20; 20litres
2	Electric motor	EM 80 0,55kW/3 B34-L
3	Pump	10A3,65X053G
4	Return filter	MPFO301AG1
5	One-way valve	CV08-20-0-N-4
6	Pressure relief valve	RV08-20A-0-N-9; 40bar
7	Pressure gauge	dia. 68 with glyc. Ax; 0-100bar
8	Switchboard	DVE03-S51-B5-C24/20/T1-M1
9	Switchboard	DVE03-S12-B2-C24/20/T1-M1
10	Pressure switch	0166 411 03 1 0043; set 13bar+-2
11	Pressure reduction valve	CPT-MD-FA/1"
12	Filling cap	PR08-32B-0-N-6; 10-40bar
13	Hydraulic lock	CVP03-B3A
	Filter insert	MF0301P10

## 11.1. Hydraulic Unit Wiring Diagram for ARG 380, 500 plus S.A.F.

### HOSE IDENTIFICATION:

- 1A, 1B - GUIDE FEED
- 2A, 2B - BLADE TENSIONING
- 3A, 3B, 4A, 4B, 5A - ARM
- 6A, 6B - VICE
- 7A, 7B - HVP

### ELECTRIC VALVES IDENTIFICATION:

- EV1 - CLAMP THE VICE
- EV2 - UNCLAMP THE VICE
- EV3 - ARM DESCENT
- EV4 - ARM DOWN -> DECELERATE
- EV5 - ARM UP
- EV6 - SAW BLADE TENSIONING
- EV7 - SAW BLADE LOOSENING
- EV8 - MOVING BLOCK TO FIXED BAR
- EV9 - MOVING BLOCK FROM THE FIXED BAR
- EV10 - 2nd PUMP (RELIEF)
- TS1 - PRESSURE SWITCH FOR BLADE TENSIONING
- TS2 - PRESSURE SWITCH FOR THE VICE

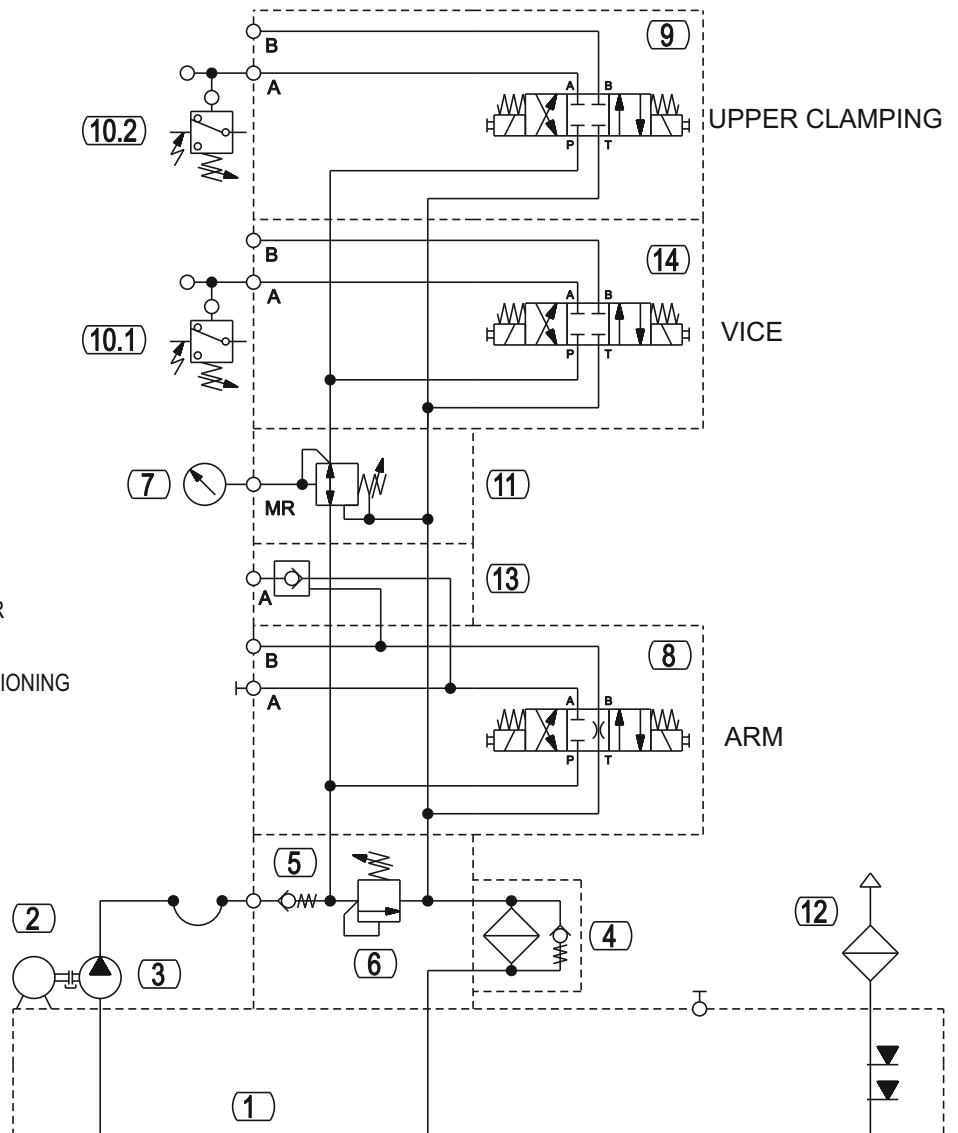

Q = 4,7 l/min  
 $p_{max}$  = 40 bar  
 P = 0,55 kW

UNIT TYPE NUMBER: S001\_106  
 UNIT CATALOGUE NUMBER:

POWER SUPPLY - BASIC PARAMETERS

Poz.	Name	Type identification
1	Tank	TM20, 20 litres
2	Electric motor	EM 71 0,55kW/3 1500 RPM B35-L
3	Pump	10A3,65X053G
4	Return filter	W79
5	One-way valve	CVG 14
6	Pressure relief valve	MO-020/10, 40 bar
7	Pressure gauge	dia. 68 with glyc. Rad., 0-100bar
8	Switchboard	DVE03-S51-B5-C24/20/T1-M1
9	Switchboard	DVE03-S01-B2-C24/20/T1-M1
10	Pressure switch	0166 411 031 043 + cap, set 13bar+-2
11	Pressure reduction valve	RV03-P-55_R_M, 0-40bar
12	Filling cap	CPT-MD-FA/1"
13	Hydraulic lock	PC08-30-0-N
14	Switchboard	DVE03-S01-B5-C24/20/T1-M1

## 12. Accessories

### 12.1. Laser Guideline Light

Laser guidance is a very practical tool for easy identification of the desired length of the cut material without a horizontal side stop both during perpendicular and angular cutting. The desired cutting spot is indicated by a red mark copying the saw blade.



#### Safety warning

Caution! Includes a 3R-class laser source. Avoid eye contact with both direct and reflected laser beam. Never look into the laser lens when the machine is in operation! Risk of permanent damage to your vision! Keep away from children.

#### Information - What is a Laser of the performance class 3R - classification according to IEC 60825

This group covers lasers that emit radiation in the continuous mode in the visible part of the spectrum, from 400 to 700 nm, and whose power does not exceed 5mW. Laser of this class cannot cause damage to the human eye in case of a fleeting glance. The eye of a healthy human is protected by the natural blink reflex, supposing the person is not under the influence of narcotic substances. It is assumed that the time that elapses between the contact with the eye and the laser beam, and the closing of the eyelids (or turning the head aside), is less than 0.25 s. That is sufficient for the retina to remain protected from the light energy of over 0.25 millijoule. The amount of 0.25 mJ is the maximum permissible value the human eye can be exposed to in case of a direct eye contact with the laser bundle. Danger arises during an intentional and a long look into the laser beam, or when observing the beam with an optical system. **It is not allowed to watch the beam with binoculars.** These lasers would cause permanent eye damage.

#### 12.1.1. Activation and deactivation of the laser beam

After unpacking, the laser guideline light is in a full working condition. After switching on the machine (according to the instruction manual of the machine), the laser beam is activated and starts to radiate. After turning off the machine (according to the instruction manual of the machine), the beam extinguishes.

#### 12.1.2. Laser indication on the machine

Each machine equipped with the laser guideline light must be indicated with a laser pictogram label.

In the proximity of the machine and the operator, a security warning must be displayed.



#### 12.1.3. Adjustment

If the laser beam does not point exactly at the cut, it needs to be adjusted.

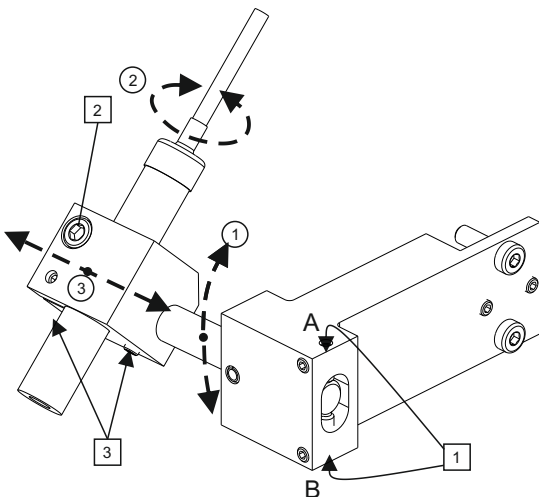

1. Switch on the machine, the laser beam starts to radiate.
2. Set up the beam as close as possible to the desired position.
3. Then, while adjusting, start moving the laser holder console ① upwards or downwards and adjust the laser beam with a descending arm so that it does not veer to one or the other side.  
If the beam veers in the direction ahead of the cut, when the shoulder is descending, loosen the setting screw 1A and tighten 1B. Or the other way round.
4. When the beam does not veer anymore and remains directed during both ascending and descending of the arm, readjust the desired direction by ② and ③.

## 12.2. Oil Mist Lubrication

When using the standard cooling equipment, coolant leakages from the machine often occur, particularly when cutting long sections. Oil mist lubrication is a device that creates oil mist, which is subsequently applied through nozzles directly onto the saw blade that is then cooled and lubricated. The device functions by dosing oil and air mixture. It is also useful in the processing of material that excludes the contact with a regular coolant. This lubrication system is lossy, so it is necessary to refill the coolant regularly.

The injection nozzle holder must be placed near the designated point in order to reach the optimum adjustment of the nozzle with the least possible distance from the lubrication point. The supplied compressed air must be absolutely dry and oil free. Optimum operating pressure is between 4 and 8 bars. Commissioning is carried out during the open subordinate actuating valve by an external signal from the control valve (optional), the connection to the mains is facilitated by a supplied screw connector (PG9). Fill the tank with COOLcut Micro liquid and the mist lubrication is ready for operation.

### Important:

In the event of use of lubricating media other than the recommended, a risk of decay or deposits arise. That is why the system functionality can only be guaranteed for the use of COOLcut Micro liquid.

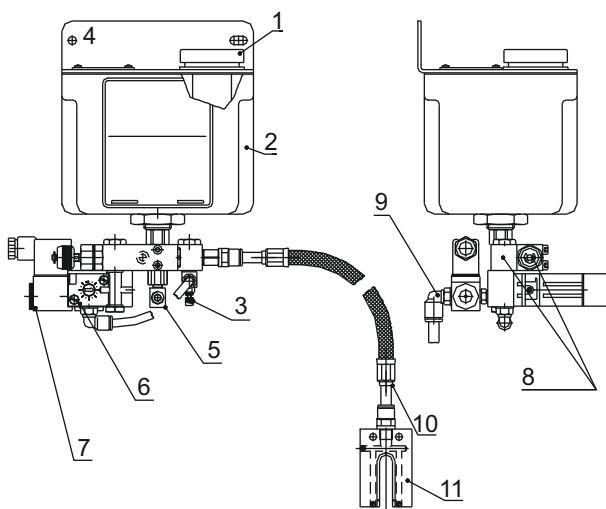

1	SCREW-ON LID WITH A FILTER
2	1.2L CONTAINER
3	OIL MIST SETTING
4	FITTING HOLE
5	VENTING
6	PULSE GENERATOR
7	SOLENOID VALVE 24V DC PG 9 SOCKET
8	DOSING PUMP
9	COUPLING 8MM
10	2.5 M COAXIAL POWER CABLE (METAL PROTECTION)
11	NOZZLE HEAD CAT. NO.: 70.107.1

### Oil mist venting

Oil mist lubrication system is supplied after testing.

Before commissioning and maintenance on the coaxial cable or nozzle, the system has to be vented. If the volume of oil in the container does not drop under the minimum threshold, other venting is not necessary.

### Venting procedure:

1. Fill the tank with a clean lubrication medium.
2. Loosen the drainage and venting screw a little and keep releasing the lubricating medium until there are no air bubbles present in it.
3. Set the pulse generator frequency to the maximum value (approx. 66 pulses per minute).
4. Set the dosing pump piston stroke to the maximum.
5. Connect the compressed air and fill the capillary tube, so that all the tubing along the whole length is bubble-free (filling duration depends on the length of tubing).
6. Connect to coaxial head to the spray head.
7. After venting, set the frequency and piston stroke to operating values again.

### Oil mist setting

1. Pulse generator settings: pneumatic time relay controls the dosing pump. You can set the frequency continuously from 0 to 66 pulses per minute.
2. Dosing pump settings: the piston vacuum pump doses the lubricating medium under high pressure. The quantity of the lubricant can be regulated by turning the manual setting wheel.
3. Oil mist spray setting: By spraying the air the drops form a very fine lubricating film and its setting influences the degree of dispersion, cooling and chips formation. Volume of air in the nozzle can be adjusted by the adjustment screw.



## DOSING PUMP SETTINGS

Piston vacuum pump doses the lubricant accurately and under high pressure.

CLICK	GROOVE No.	SUPPLIED VOLUME/STROKE
0	1	41 mm <sup>3</sup>
4	2	30 mm <sup>3</sup>
8	3	23 mm <sup>3</sup>
12	4	16 mm <sup>3</sup>
16	5	9 mm <sup>3</sup>
18	6	2 mm <sup>3</sup>
20	7	0 mm <sup>3</sup>

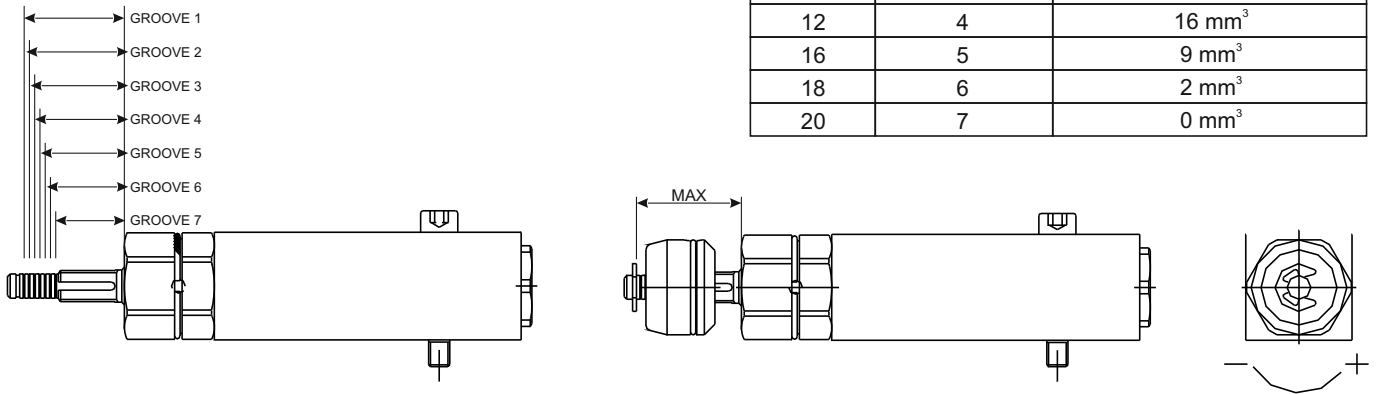

## PULSE GENERATOR SETTINGS 6 BAR (90 PSI)

66 PULSES  
PER MINUTE

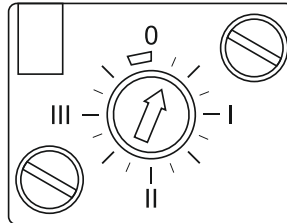

37 pulses per minute	21 pulses per minute	13 pulses per minute	10 pulses per minute	6 pulses per minute	5 pulses per minute

4 pulses per minute	3 pulses per minute	2,5 pulses per minute	2 pulses per minute	1,5 pulses per minute	1 pulse per minute

### 12.3. Vertical vice for HVP bundle cutting

The HVP vertical vice facilitates are used for cutting of materials in bundles. Proper and sufficient clamping of all workpieces in the bundle significantly influences the service life of the saw blade. The contact pressure plate facilitates vertical clamping of the workpiece. If a larger bearing surface is required, mount your own fixture of corresponding dimensions onto the contact pressure plate. Make sure that the guide rods are locked by fixation screws before you start cutting. **Check whether the workpiece is properly clamped, otherwise you risk its ejection during cutting!**

**WARNING!** When using the vertical vice while cutting the workpieces in HVP bundles, you can cut only at 90°.

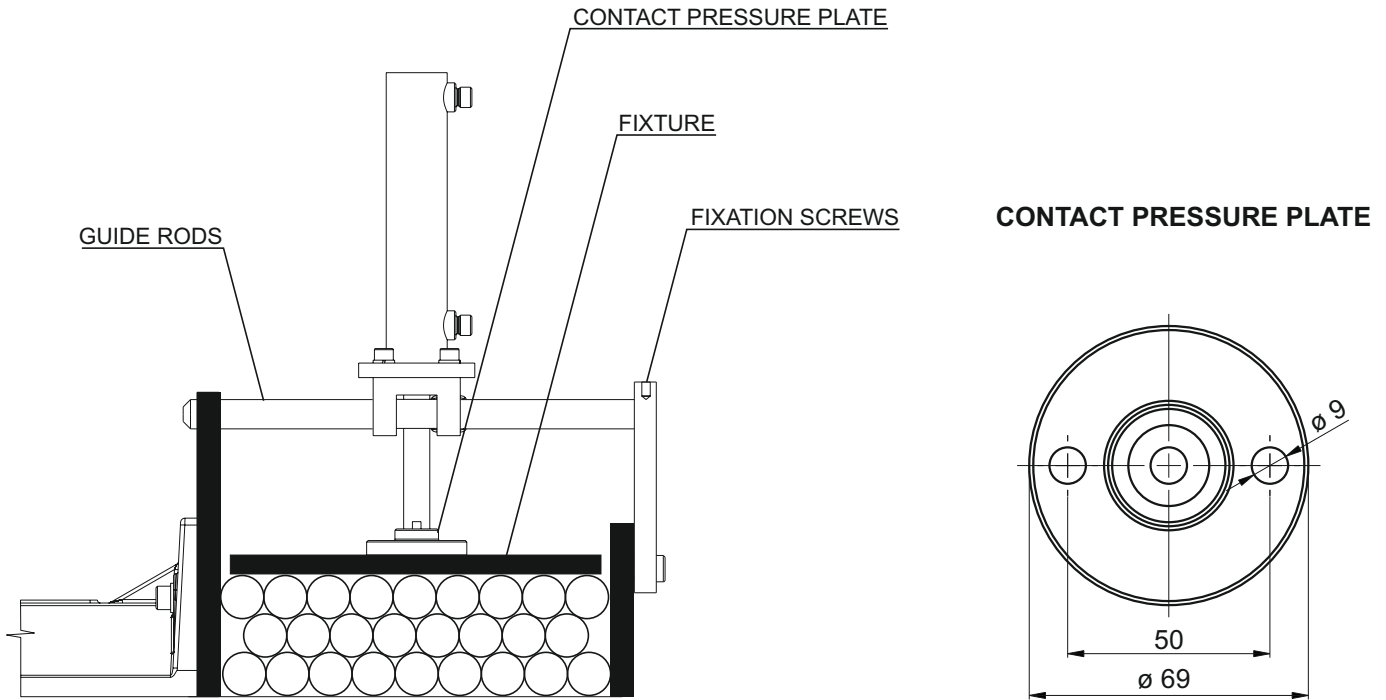

The HVP packet for one-directional swing saw ARG 330 S.A.F. includes a new movable clamping jaw and also a small clamping jaw that has to be connected onto a pre-drilled cast iron fixed clamping jaw in front of the cutting line.

The HVP packet for double-directional swing saw ARG 330 plus S.A.F. includes a new movable clamping jaw and also a small clamping jaw that has to be connected onto a pre-drilled cast iron fixed clamping jaw in front of the cutting line. Longitudinal rods are usually supplied in three pieces, in order to allow for cutting of a whole range of sections. It is necessary to replace the rod before cutting in order to prevent collision with the guide head or clamping jaw.

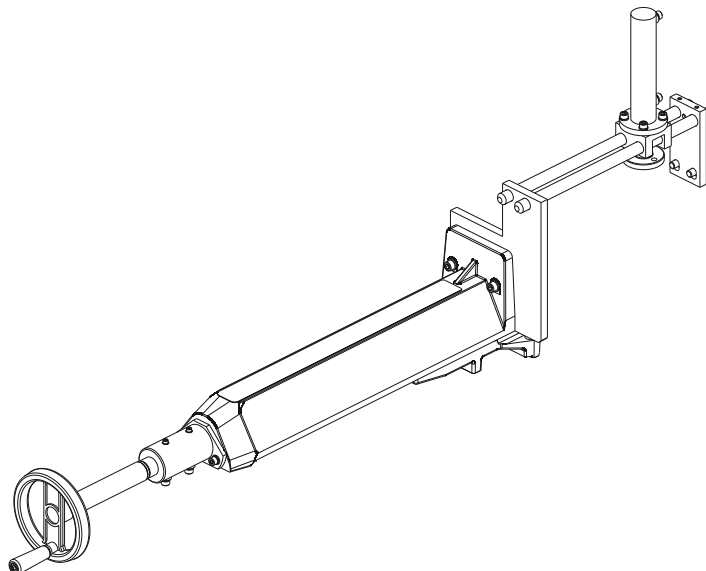

The HVP packet for double-directional swing saw ARG 380 plus S.A.F., ARG 400 plus S.A.F., ARG 500 plus S.A.F. has been designed so that there is no need for further mechanical adjustments. When fixing the HVP, make sure that the fixation handle does not collide with the saw blade/guide head during the ascending/descending of the arm.

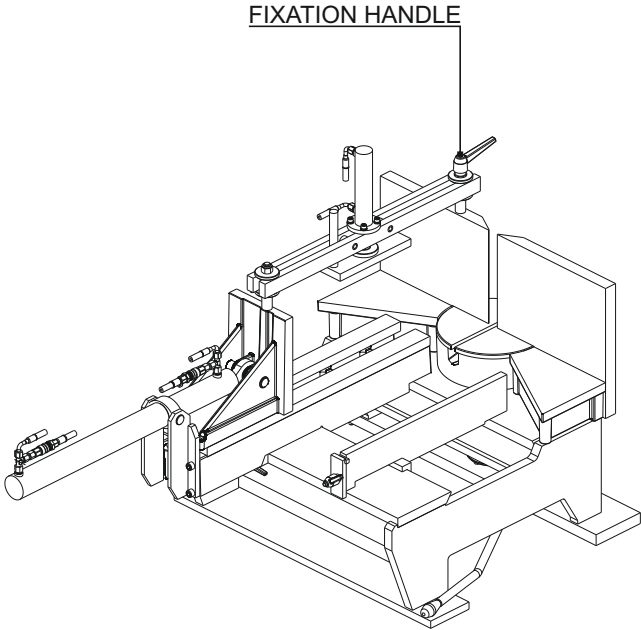
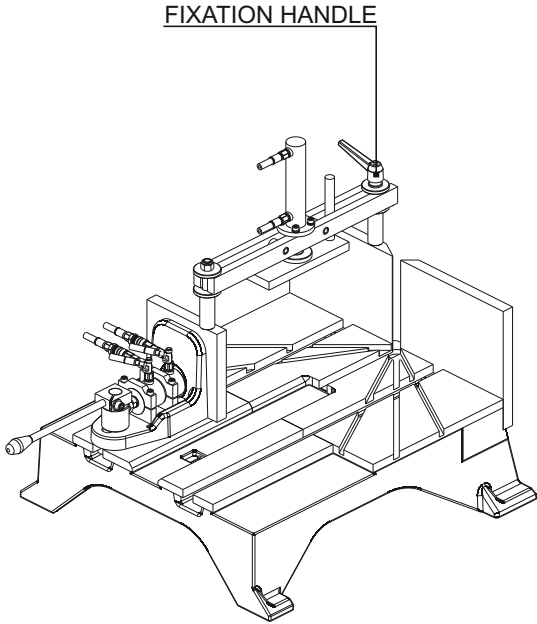

# EU Declaration of Conformity

in accordance with Directive 2006/42/EC of the European Parliament and of the Council (Government Regulation No. 176/2008 Coll.)  
in accordance with Directive 2014/35/EU of the European Parliament and of the Council (Government Regulation No. 118/2016 Coll.)  
in accordance with Directive 2014/30/EU of the European Parliament and of the Council (Government Regulation No. 117/2016 Coll.)

**Manufacturer: Pilous-pásové pily, spol. s r.o., Železná 9, Brno 619 00, CZ, VAT: CZ60727551**

**Identification data of the machine:** Band saw including accessories

**Type:** ARG 330 S.A.F., ARG 330 plus S.A.F., ARG 380 plus S.A.F., ARG 400 plus S.A.F., ARG 500 plus S.A.F.

**Description and designation of product function:** The band saw is intended for cutting primarily metal materials, while the workpiece is clamped in a fixed vice and the cutting is carried out by a saw blade arm.

**All applicable provisions the machine is in compliance with:**

- Directive 2006/42/EC of the European Parliament and of the Council
- Directive 2014/35/EU of the European Parliament and of the Council
- Directive 2014/30/EU of the European Parliament and of the Council

**Applied harmonized standards, national standards and technical specifications:**

- EN ISO 12100:2011
- EN ISO 14120:2016
- EN ISO 4413:2011
- EN 50370 - 1:2005
- EN 50370 - 2:2003
- EN 61000-6-1 ed.2:2007
- EN 61000-6-3 ed. 2 +A1+rev.1:2013
- EN ISO 11202:2011
- EN ISO 3746:2011
- EN 614-1+A1:2009
- EN 13898+A1+rev.1:2010
- EN ISO 14119+rev.1:2015
- EN 60204-1 ed.2+A1+rev.1:2011
- EN 349+A1:2009
- EN ISO 13857+rev.1:2010
- EN 1037+A1:2009
- EN ISO 13849-1+rev.3:2015

**Person responsible for drawing up technical documentation:** Ing. Petr Mašek

name, company address: **Pilous-pásové pily, spol. s r.o., Železná 9, Brno 619 00, CZ, VAT: CZ60727551**

**Person responsible for drawing up EU Declaration of Conformity:** Ing. Petr Mašek

name, company address: **Pilous-pásové pily, spol. s r.o., Železná 9, Brno 619 00, CZ, VAT: CZ60727551**

**The manufacturer declares that the machine complies with all relevant provisions of this regulation (Directive) declares that the machine is in compliance with other regulations (Directives) which apply to the product. This declaration of conformity is issued under the sole responsibility of the manufacturer.**

**This EU Declaration of Conformity is original EU Declaration of Conformity.**

**The last two digits of the year in which the CE mark was placed on the product: 16**

**Serial number:**

In Brno, on: 1.6. 2016

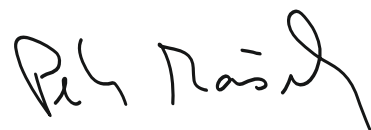

person authorized to act on our behalf  
Ing. Petr Mašek  
Managing Director